

Operating Instructions

Minebea Intec IS-X

**Models IS06BBE-SX, IS2CCE-SX, IS6CCE-HX,
IS6CCE-SX, IS12CCE-SX, IS16EDE-HX, IS34EDE-HX, IS64EDE-
SX, IS150IGG-HX, IS300IGG-HX and Verifiable Models**

Weighing Platforms for Use in Hazardous Areas/Locations

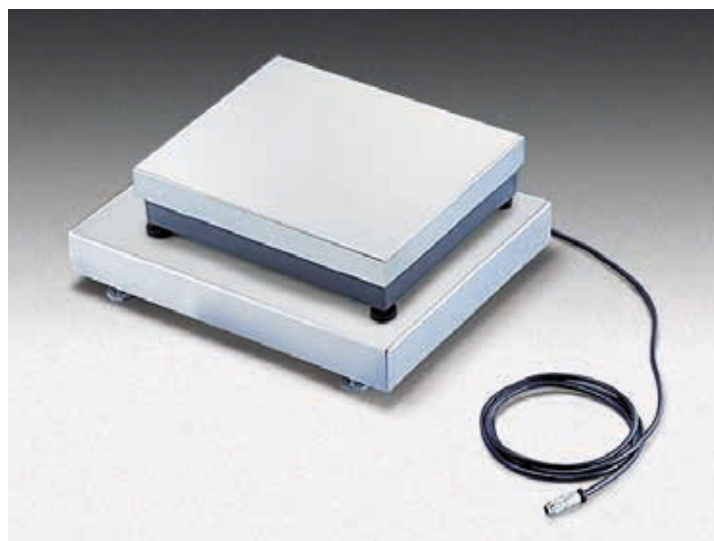
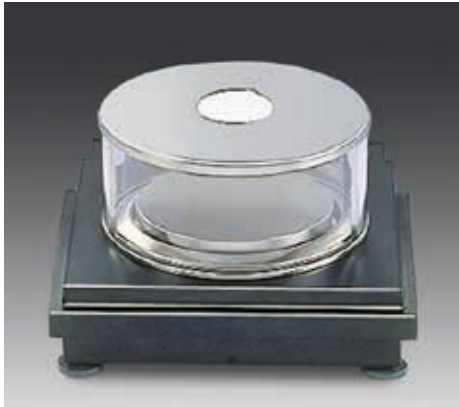

Contents

- 2 Intended Use
- 3 Operating Limits
- 4 Tables of Specifications
- 9 Pin Assignment Chart
- 10 Troubleshooting Guide
- 11 Accessories (Options)
- 12 General View of the Equipment
- 15 Dimensions (Scale Drawings)
- 20 Declarations of Conformity
- 26 Certificates for Operation of the Weighing Platform in Hazardous Areas

Symbols

The following symbols are used in these instructions:

- indicates required steps
- indicates steps required only under certain conditions
- > describes what happens after you have performed a certain step
- indicates an item in a list
- △ indicates a hazard

Make sure you observe the warning and safety information in its entirety during installation and operation, as well as while performing maintenance and repair work on the equipment. It is important that all personnel using the equipment understand this information, and have access to it at all times. The warning and safety information is contained in the 11-language installation manual included with the equipment.

The warning and safety information can be supplemented by the equipment operator. Make sure all operating personnel are informed of any additions to these instructions.

Intended Use

The series IS...-X models are precision weighing platforms for weighing

samples in hazardous areas/locations. Series IS...-X equipment and connected accessories are intended to be used exclusively for weighing.

Instructions for installing the equipment and putting it into operation are contained in the enclosed 11-language installation manual.

Important Note:

The verifiable models („IS...-XCE“) can be verified for use as a scale only when connected to a display and control unit, indicator or terminal.

The following features make the IS...-X weighing platforms ideal for use as inspection, measuring and test instruments in quality management systems:

- isoTEST calibration and adjustment function
- ISO/GMP-compliant documentation functions

IS...-X weighing platforms save work and speed up both simple and complex routine procedures through the following features:

- Ultrafast response times
- Connection to a PC in a PLC or other control system

IS...-X weighing platforms meet the highest requirements placed on the accuracy and reliability of weighing results through the following features:

- Efficient filtering-out of vibration
- Stable and reproducible results
- Rugged, durable weighing system
- Weighing platform and accessories approved for use in hazardous areas/locations (see the table in the 11-language installation instructions)

All power supplies or AC adapters may be connected only to an electrical outlet (mains supply) with at least 90V and no more than 264V (48 – 62 Hz).

Set up the explosion-protected IS...-X series weighing platform and its accessories in accordance with acknowledged technical regulations. You must also comply with the national laws and safety regulations of your country.

Data Output

The weighing platform is equipped with an RS-485 data interface (RS-232 available on request) which can be used to connect any of the following:

- Printer*
- Peripheral device (such as a computer)*
- Universal remote switch

* connected through a Zener barrier (see „Accessories“)

Hotline/Technical Advice on Applications

Phone: +49 (0) 40/67960444
Fax: +49 (0) 40/67960474

E-mail: technical.support.hh@minebea-intec.com

Operating Limits

Overload Capacity

Thanks to the rugged construction of Minebea Intec weighing platforms, the weighing system will not be damaged if the maximum weighing capacity is occasionally exceeded.

The table below lists the maximum overload capacity of each weighing platform model:

IS06BBE-SX..	IS2CCE-SX..	IS6CCE-SX..
3 kg	12 kg	25 kg
IS16EDE-HX	IS150IGG-HX,	
IS34EDE-HX	IS300IGG-HX	
IS64EDE-SX		
130 kg	600 kg	

Shock Resistance

Even though Minebea Intec weighing platforms feature highly rugged construction, there are some limits. Avoid exposing the system to falling objects, side impact, or shocks. The weighing platform meets the mechanical requirements of IEC 68 Part 2-27.

Notes on Integration into Conveyor Systems

The weighing platform is suitable for installation in conveyor systems. Make sure to observe the following notes as well as the equipment dimensions when choosing components to be mounted on your weighing platform (see „Dimensions (Scale Drawings)“ in this manual).

Any moving or rotating parts intended to be permanently attached to the load plate must be designed so that they cannot affect the weighing results. For example, rotating mechanisms must be properly balanced.

The load plate must be clear on all sides so that any parts or any dirt that falls will not create a connection between the weighing platform and any permanently mounted preload components.

Any cables or tubing between the weighing platform and other equipment must not apply any force to the weighing platform. Make sure that

cables do not touch the load plate. Special care must be taken to prevent the build-up of static electricity caused by moving parts (such as roller conveyors).

Preload Range (Zero-setting Range)

The weight of components permanently attached to the weighing platform is known as the „preload.“ The preload is electronically compensated up to a defined value. Thus the entire weighing capacity is available, and it is possible to zero or calibrate/adjust the weighing system (with external weights). A preload heavier than the defined value may result in a reduction of the weighing capacity.

The maximum preload that can be compensated depends on the specification block configured (refer to the tables of specifications below). Components attached to the weighing platform must be installed before the weighing platform is connected to power.

Configuring the Weighing Platform

The weighing platform can be configured to meet individual requirements, such as weighing in international units, weighing in unfavorable ambient conditions, or external electronic processing of weight values. This means the final configuration of a unit can be performed by the weighing equipment dealer or the end user.

The weighing platform is adapted for individual requirements using the configuration menu in the connected display and control unit or indicator. The weighing platform can also be configured using a connected computer running the Minebea Intec configuration program (see „Accessories“).

Options Available for Weighing Range Configuration

SuperRange

This range divides the weighing capacity of the platform into 50.000 intervals, an exceptionally high resolution. The readability is identical over the entire weighing range (for example, 1 g).

SingleRange







The weighing range is divided into up to 50.000 intervals. The readability is identical over the entire weighing range (for example, 10 g).

Multi-interval/DualRange

Intervals with adjusted accuracy. These functions divide the weighing capacity into as many 3 weighing ranges, each with a different readability.

The weight readout is shown with different levels of accuracy in each range. The platform changes from one range to another automatically when the load on the platform is changed (the readability in each range is listed in the tables of specifications below). Once the platform has been tared, the highest possible resolution is available even if the weighing platform is loaded. The configuration options available for each weighing platform are listed below, in the section entitled „Tables of Specifications.“

Tables of Specifications

Model SX		IS06BBE-SX	IS2CCE-SX	IS6CCE-HX	IS6CCE-SX	IS12CCE-
Readability	g	0.001	0.01	0.01	0.1	0.1
.....						
Weighing capacity	g	620	2200	6200	6200	12,000
Max. overload capacity	kg	3	12	12	25	25
Tare range (subtractive)	g	- 620	- 2200	- 6200	- 6200	- 12000
Preload (can be electronically compensated without reducing the weighing capacity)	g	93	110	-	1240	1200
Max. preload at start of isoTEST calibration/adjustment (platform must be zeroed)	g	110	1300	5200	6400	10000
Repeatability	<±g	0.001	0.01	0.01	0.05	0.05
Linearity	<±g	0.002	0.02	0.02	0.1	0.2
Sensitivity drift within +10 to +30 °C	<±/K	2 • 10 ⁻⁶	2 • 10 ⁻⁶	2 • 10 ⁻⁶	4 • 10 ⁻⁶	4 • 10 ⁻⁶
Response time (average)	s	1.5	1.5	1.5	1	1
External calibration weight (of at least accuracy class...)	g	500 (E2)	2000 (F1)	5000 (E2)	5000 (F2)	5000 (F1)
Load plate dimensions	mm	Ø 130	218 x 200 218 x 200 218 x 200			
Platform dimensions (W x D x H)	mm	240x294x86	240x294x86	240x294x86	240x294x86	240x294x86
Net weight, approx.	kg	7	7.3	8.4	7.3	7.3
Dust and water protection rating for the housing acc. to EN 60529			IP44			
AC power		source Power supply model YPS02-X or AC adapter model YPS02-Z (100-240V) (must be connected by the weighing equipment dealer or a Minebea Intec service technician)				
Frequency	Hz	48 - 62				
Allowable ambient operating temperature		0 °C to +40 °C (273 °K to 313 °K; 32 °F to 104 °F)				
Operating temperature range		+10 °C to +30 °C (or 0 °C to +40 °C; depends on configuration)				
Adaptation to ambient conditions		By selection of 1 of 4 optimized filter levels				
Display update (depends on filter level selected)		0.1 - 0.1 - 0.2 - 0.4 (normal output rate)				
Power consumption		Average: 25VA				
Selectable weight units:		Grams, kilograms, carats, pounds, ounces, Troy ounces, Hong Kong taels, Singapore taels, Taiwanese taels, grains, pennyweights, milligrams, parts per pound, Chinese taels, mommes, Austrian carats, tola, baht and mesghal				
Built-in RS-485 interface		(standard equipment; xBPI protocol): 8 bits, odd parity; transmission rate: 9600 - 38,400 baud; half-duplex; convertible to RS-232 (SBI protocol): 7 bits, Parity: even, odd, mark, space; transmission rates: 150 - 19,200 baud; 1 or 2 stop bits, software/hardware handshake; factory settings: 1200 baud, odd parity, 1 stop bit, hardware handshake with 2 characters after CTS				
Model series Marking (ATEX)	Use in	IP rating Zone	Markings in acc. with FMRC approval for USA and CSA approval for Canada		Use in	
IS.. BBE-.X..	1, 2 (gas)	IP 54	IS CL I, DIV 1, GR A,B,C,D, T4		Class I, Division 1 (gas)	
 II 2 G EEx ib IIC T4			CL I, ZONE 1 AEx ib IIC T4		Class I, Zone 1 (gas)	
IS.. CCE-.X..	1, 2 (gas)	IP 54	IS CL I, DIV 1, GR A,B,C,D, T4		Class I, Division 1 (gas)	
 II 2 G EEx ib IIC T4			CL I, ZONE 1 AEx ib IIC T4		Class I, Zone 1 (gas)	
IS... EDE-.X..	1, 2 (gas)	IP 65	IS CL I, DIV 1, GR A,B,C,D, T4		Class I, Division 1 (gas)	
 II 2 G EEx ib IIC T4			CL I, ZONE 1 AEx ib IIC T4		Class I, Zone 1 (gas)	
	20, 21, 22	IP 65	IS CL II,III, DIV 1, GR E,F,G, T4		Class II,III Division 1	
 II 1 D T135°C (dust)					(dust+ fibers)	
IS64EDE-HX..	1, 2 (Gas)	IP 44	IS CL I, DIV 1, GR A,B,C,D, T4		Class I, Division 1 (gas)	
 II 2 G EEx ib IIC T4			CL I, ZONE 1 AEx ib IIC T4		Class I, Zone 1 (gas)	
IS... IGG-HX	1, 2 (gas)	IP 65 and IP67	IS CL I, DIV 1, GR A,B,C,D, T4		Class I, Division 1 (gas)	
 II 2 G EEx ib IIC T4			CL I, Zone 1 AEx ib IIC T4		Class I, Zone 1 (gas)	
 II 1 D T135°C	20, 21, 22	IP 65 and IP 67	IS CL II,III, DIV 1, GR E,F,G, T4		Class II,III Division 1	
	(dust)				(dust + fibers)	

* = factory setting

HX-Mode	IS16EDE-HX	IS34EDE-HX	IS64EDE-SX	IS64EDE-HX	IS150IGG-HX	IS300IGG-HX
Readability	g 0,1	0,1	1	0,1	1	2
Weighing capacity	kg 16	34	64	64	150	300
Max. overload capacity	kg 130	130	130	130	600	600
Tare range (subtractive)	kg - 16	- 34	- 64	-64	- 150	-300
Preload (can be electronically compensated without reducing the weighing capacity)	kg 4	4	13	13	20	60
Max. preload at start of isoTEST calibration/adjustment (platform must be zeroed)	kg ca. 19	ca. 21	ca. 45	45	-	-
Repeatability	<±g 0,05	0,1	0,5	0,2	1	2
Linearity	<±g 0,2	0,2	1	1	4	8
Sensitivity drift within +10 to +30 °C	<±/K2 • 10 ⁻⁶	2 • 10 ⁻⁶	3 • 10 ⁻⁶	3 • 10 ⁻⁶	2,5 • 10 ⁻⁶	2,5 • 10 ⁻⁶
Response time (average)	s 1,5					
External calibration weight (of at least accuracy class...)	kg 10 (F1)	10 (F1)	10 (F2)	10 (F1)	50 (F2)	50 (F2)
Operating temperature range	°C 10...30	10...30	0...40	0...40	0...40	0...40
Load plate dimensions	mm300 x 400	300 x 400	300 x 400	300 x 400	800x600	800x600
Net weight, approx.	kg 16	16	16	16	70	70
Dust and water protection rating of the housing acc. to EN 60529	IP65	IP65	IP65	IP44	IP67	IP67
AC power source	Power supply model YPS02-X or AC adapter model YPS02-Z (100-240V) (must be connected by the weighing equipment dealer or a Minebea Intec service technician)					
Frequency	Hz 48 - 62					
Allowable ambient operating temperature	0 °C to +40 °C (273 °K to 313 °K; 32 °F to 104 °F)					
Operating temperature range	+10 °C to +30 °C (or 0 °C to +40 °C; depends on configuration)					
Adaptation to ambient conditions	By selection of 1 of 4 optimized filter levels					
Display update (depends on filter level selected)	0.1 - 0.1 - 0.2 - 0.4 (normal output rate)					
Power consumption	Average: 25VA					
Selectable weight units:	Grams, kilograms, carats, pounds, ounces, Troy ounces, Hong Kong taels, Singapore taels, Taiwanese taels, grains, pennyweights, milligrams, parts per pound, Chinese taels, mommes, Austrian carats, tola, baht and mesghal					
Built-in RS-485 interface	(standard equipment; xBPI protocol): 8 bits, odd parity, transmission rate: 9600 - 38,400 baud; half-duplex; convertible to RS-232 (SBI protocol): 7 bits, Parity: even, odd, mark, space; transmission rates: 150 - 19,200 baud; 1 or 2 stop bits, software/ hardware handshake; factory settings: 1200 baud, odd parity, 1 stop bit, hardware handshake with 2 characters after CTS					

* = factory setting

IS „-XCE“ Series Verifiable Models				
Model		IS06 BBE-SXCE	IS2 CCE-SXCE	IS6 CCE-HXCE
Readability	g	0.001	0.01	0.01
Weighing capacity	g	620	2200	6200
Max. overload capacity	kg	3	12	12
Tare range (subtractive)	g	- 620	- 2200	- 6200
Preload (can be electronically compensated)	g	93	110	-
..... without reducing the weighing capacity)				
Max. preload at start of isoTEST calibration/adjustment (weighing inst. must be zeroed)	g	110	1300	5200
Repeatability	<±g	0.001	0.01	0.01
.....				
Linearity	<±g	0.002	0.02	0.02
Sensitivity drift within +10 to +30 °C	<±/k	2 • 10 ⁻⁴	2 • 10 ⁻⁴	2 • 10 ⁻⁴
Response time (average)	s	1.5	1.5	1.5
External calibration weight (of at least accuracy class...)	g	500 (E2)	2000 (F1)	5000 (E2)
Accuracy class		Ⓔ	Ⓔ	Ⓔ
Type.		BD BF	BD BF	BD BF
Verification scale interval	g	0.01	0.1	0.1
Minimum capacity acc. to prepackage regulations*	g	0.02	0.5	0.5
Operating temperature range	°C	10 to 30 (50 to 86°F)	10 to 30 (50 to 86°F)	10 to 30 (50 to 86°C)
Load plate dimensions	mm	Ø 130	218 x 200	218 x 200
Platform dimensions (WxDxH)	mm	240x294x86	240x294x86	240x294x86
Net weight, approx.	kg	7	7.3	8.4
Dust and water protection rating for the housing acc. to EN 60529		IP44		
AC power source		Power supply model YPS02-X or AC adapter model YPS02-Z (100-240V); YRB02-Z (rechargeable battery), YPS02-XV24 (24V)		
Frequency	Hz	48 - 62		
Adaptation to ambient conditions		By selection of 1 of 4 optimized filter levels		
Display update (depends on filter level selected)		0.1 - 0.1 - 0.2 - 0.4 (normal output rate)		
Power consumption		Average: 25VA		
Built-in RS-485 interface		(standard equipment; xBPI protocol): 8 bits, odd parity, transmission rate: 9600 - 38,400 baud; half-duplex; convertible to RS-232 (SBI protocol): 7 bits, parity: even, odd, mark, space; transmission rates: 150 - 19,200 baud; 1 or 2 stop bits, software/hardware handshake; factory settings: 1200 baud, odd parity, 1 stop bit, hardware handshake with 2 characters after CTS		

* = factory setting

Verifiable Models, IS Series	IS16EDE-HXCE	IS34EDE-HXCE	IS64EDE-SXCE	IS150IGG-HXCE	IS300IGG-HXCE
Readability in g	0,1	0,1	1	1	20
Weighing capacity in kg	16	34	64**	150**	300**
Max. overload capacity in kg	130	130	130	600	600
Tare range (subtractive) in kg	- 16	- 34	- 64	- 150	-300
Preload (can be electronically compensated in kg without reducing the weighing capacity)	4	4	13	20	20
Max. preload at start of isoTEST calibration/adjustment (weighing inst. must be zeroed) in kg	ca. 19	ca. 21	ca. 45	-	-
Repeatability	<±g 0,05	0,1	0,3	1	5
Linearity	<±g 0,2	0,2	1	4	8
Sensitivity drift within +10 to +30 °C	<±/K $2 \cdot 10^{-6}$	$2 \cdot 10^{-6}$	$3 \cdot 10^{-6}$	$2,5 \cdot 10^{-6}$	$2,5 \cdot 10^{-6}$
Response time (average)	s 1,5	1,5	1,5	1,5	1,5
External calibration weight (of at least accuracy class...)	g 10000 (F1)	10000 (F1)	10000 (F2)	50000 (F2)	100000(F2)
Accuracy class	Ⓜ	Ⓜ	Ⓜ	Ⓜ	Ⓜ
Type	BF BF	BF BF	BF BF	HC BF	HC BF
Verification scale interval	g 1	1	10	10	20
Minimum capacity acc. to prepackage regulations*	g 5	5	50	50	100
Mindestlast nach FPV	g 150	150	-	-	-
Operating temperature range	°C 10...30 (50 to 86°F)	10...30 (50 to 86°F)	10...30 (50 to 86°F)	10...30 (50 to 86°F)	10...30 (50 to 86°F)
Load plate dimensions	mm 300 x 400	300 x 400	300 x 400	800x600	800x600
Net weight, approx	kg 16	16	70	70	70
Dust and water protection rating of the housing acc. to EN 60529	IP65	IP65	IP65	IP67	IP67
AC power source	Power supply model YPS02-X or AC adapter model YPS02-Z (100-240V); YRB02-Z (rechargeable battery), YPS02-XV24 (24V)				
Frequency	Hz 48 - 62				
Adaptation to ambient conditions	By selection of 1 of 4 optimized filter levels				
Display update (depends on filter level selected)	0.1 - 0.1 - 0.2 - 0.4 (normal output rate)				
Power consumption	Average: 25VA				
Built-in RS-485 interface	(Standard equipment; xBPI protocol): 8 bits, odd parity, transmission rate: 9600 - 38,400 baud; half-duplex; convertible to RS-232 (SBI protocol): 7 bits, parity: even, odd, mark, space; transmission rates: 150 - 19,200 baud; 1 or 2 stop bits, software/hardware handshake; factory settings: 1200 baud, odd parity, 1 stop bit, hardware handshake with 2 characters after CTS				

* = factory setting

** = variable weight unit kg, t

Pin Assignment Chart

Female Interface Connector:

14-contact round female connector with screw lock hardware for cable gland

Pin Assignments

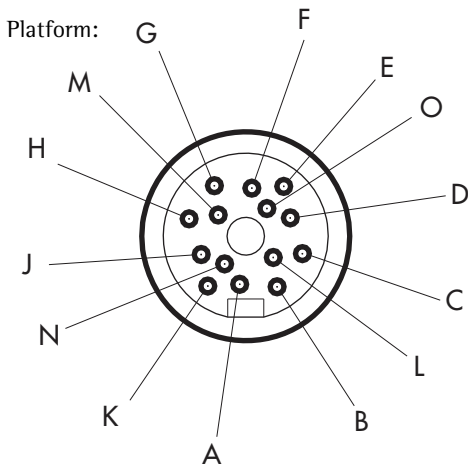

Zener barrier (output in safe area)
YDI01-Z, YDI02-Z, YDI03-Z:

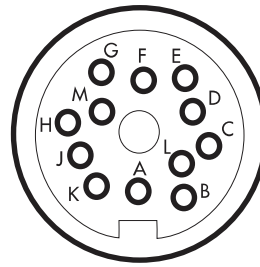

14-pin Round male connector	Barrier	12-pin	Signal RS-232 ¹⁾ (SBI and xBPI)	Signal RS-485 (xBPI)
G		A	Control output „heavier“	Control output „heavier“
K		B	Data output (TxD)	RxD – TxD – N
J		C	Data input (RxD)	RxD – TxD – P
N		D	Data terminal ready (DTR)	
M		E	Signal GND	Signal GND
F		G ³⁾	Control output „lighter“	Control output „lighter“
A		H	Clear to send (CTS)	
E		J ³⁾	Control output „equal“	Control output „equal“
O		–	Universal switch ²⁾	Universal switch ²⁾
D		L ³⁾	Control output „set“	Control output „set“

Provide a low-resistance connection between shield and connector casing.

¹⁾ RS-232-interface available on request

²⁾ Function: see „External Universal Remote Switch“ in the section entitled „Extra Functions.“

³⁾ YDI03-Z only

Important:

⚠ Only electrical apparatus with a max. voltage U_m of 250V may be connected to the Zener barrier. The Zener voltage U_z is 12V.

Troubleshooting Guide

Problem	Possible cause(s)	Solution
No segments are shown on the display	No AC power is available	Check the AC power supply; connect the power supply/AC adapter to power
	The power supply or AC adapter is not connected	
Weight display shows "H"	Device not used > 5 minutes (now in stand-by mode)	Turn on the display and control unit/indicator using the On/Off switch
	The load exceeds the weighing capacity	Unload the weighing platform
Weight display shows "L" or "Err 54"	The load plate is not in position	Place the load plate on the platform
Weight display shows "Err 01" briefly	Data output not compatible with output format	Change the menu settings in device setup menu
Weight display played shows "Err 02" briefly	One of the conditions for calibration was not met	Calibrate only when zero is displayed
	Load on weighing platform	Zero the weighing platform
Weight display then shows "Err 03" briefly	Calibration/adjustment could not be performed within the required time period	Unload the weighing platform Allow the scale to warm up and repeat calibration/adjustment
	The load on the weighing platform is too heavy to allow the platform to be zeroed	Check whether your configuration meets the zero-setting point requirements
Error code "Err 08"	The load on the weighing platform is too heavy to allow the platform to be zeroed	Zero the weighing platform
Error code "Err 09"	Gross value < zero and weighing platform is unloaded, but cannot be tared	Zero the weighing platform
Error code "Err 10"	Data in application tare memory when attempted to clear lower tare memory	Clear the application tare
Error code "Err 12"	Attempt to write data in application tare memory when blocked (menu item 2 2 x)	Check configuration memory first
	Value not permitted for manual tare input	Check value entered
Error code "Err 17"	Internal calibration/adjustment not possible because preload is too high	Reduce preload or Select a different configuration
Error code "Err 19"	The available weighing capacity is too low; max. capacity reduced by high preload	Reduce preload or select a different configuration
	The special code "◆" remains on the display; none of the keys has been pressed since the equipment was switched on	Press a key
The weight readout changes constantly	Unstable ambient conditions (too much vibration, or the weighing platform is exposed to a draft)	Set up the weighing platform in a different area, or access the Setup menu to change device configuration
	A foreign object is caught between the load plate and the weighing platform housing	Remove the foreign object
The weight readout is obviously wrong	The weighing platform has not been calibrated	Perform calibration/adjustment
	The platform was not tared before weighing	Tare before weighing

If any other errors occur, please contact your local Minebea Intec office or dealer or the Minebea Intec Service Center.

Accessories (Options)



Power supply, flameproof, for use in hazardous area/location
100 - 240V

EU
GB
USA/CDN

Order no.:
YPS02-XDR
YPS02-XGR
YPS02-XKR



AC adapter for use outside the hazardous area/location
100 - 240V

EU
GB
USA/CDN

YPS02-ZDR
YPS02-ZGR
YPS02-ZKR

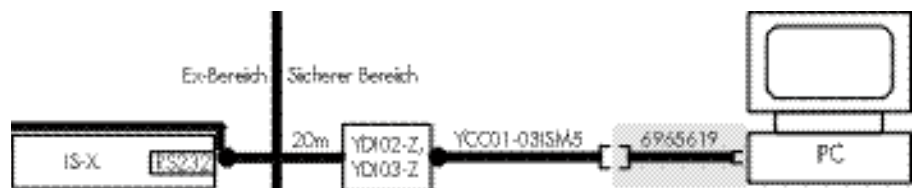

In the safe area (outside the hazardous area/location), accessories can be connected through a Zener barrier.



Data output: RS-232 for IS-X
Data output: TTY/10mA for IS-X

Zener barrier
(2 RS-485 data lines) for
connection in a bus network

Zener barrier
(4 RS-232 data lines)

Zener barrier
(4 RS-232 data lines
and 4 control lines)

Configuration program (on diskette) for IS-X weighing platform
(PC, DOC) without interface cable

Sartonet cable

Sartonet connection box

Round plug-in connector

Order no.:
YD055IS-X
YD001F-X
YDI01Z

YDI02Z

YDI03Z

YAD01IS

6906926

72583

69Y03166

For customized cable solutions or accessories, please contact the Minebea Intec.

General View of the Equipment

IS06BBE-SX

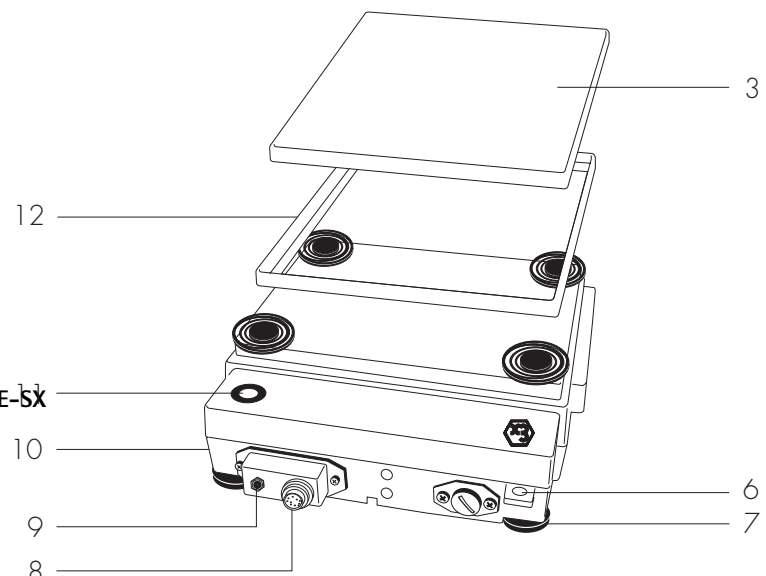
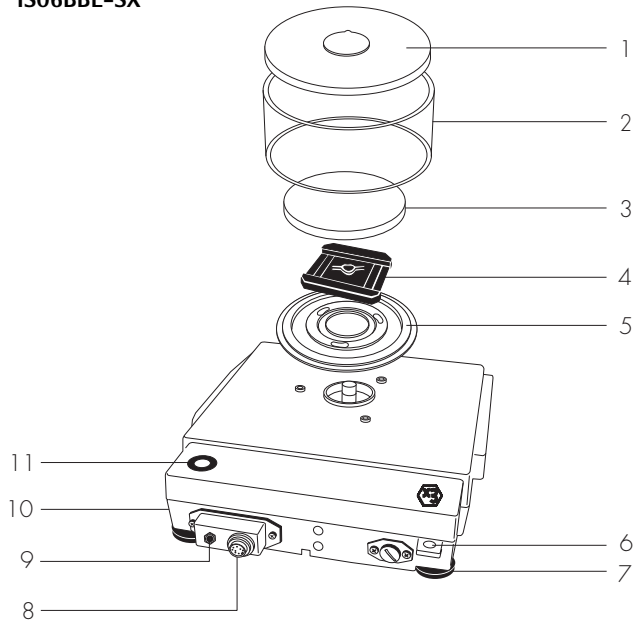

IS2CCE-SX, IS6CCE-HX, IS6CCE-SX, IS12CCE-SX

Pos.	Designation
1	Draft shield cover
2	Glass draft shield
3	Load plate
4	Pan support
5	Shield ring
6	Lug for attaching an antitheft locking device
7	Leveling foot
8	DC jack
9	Data interface (RS-485)
10	Menu access switch (under protective threaded cap)
11	Level indicator
12	Pan draft shield (models IS2CCE-SX, S6CCE-HX only)

IS16EDE-HX, IS34EDE-HX, IS64EDE-SX

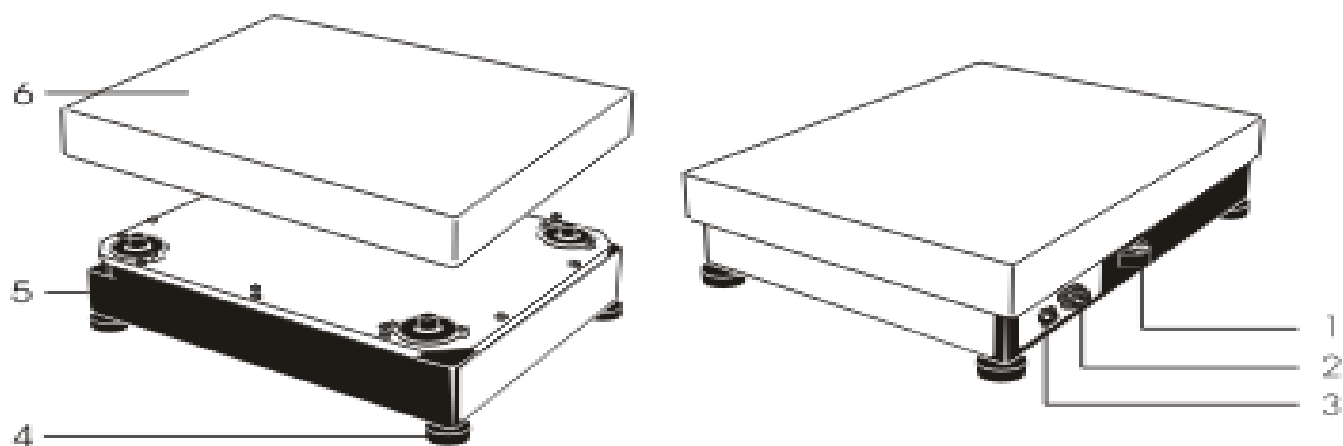

- 1 Level indicator
- 2 DC jack
- 3 Data interface (RS-485)
- 4 Leveling feet
- 5 Weighing platform
- 6 Load plate

IS150IGG-HX, IS300IGG-HX

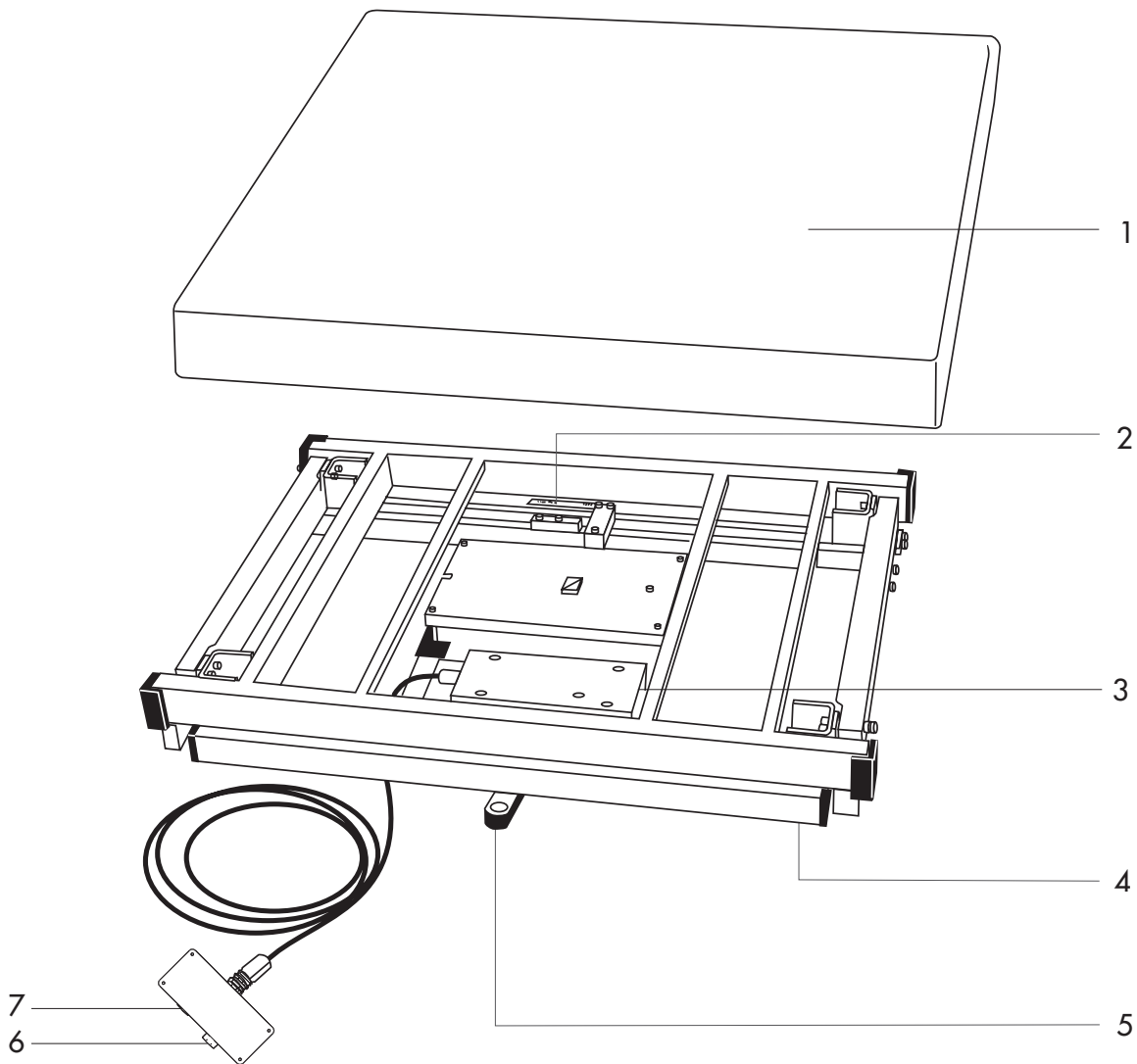

Pos. Designation

- 1 Load plate
- 2 Manufacturer's ID label
- 3 DC jack (optional)
- 4 Leveling feet
- 5 Level indicator
- 6 DC jack
- 7 Data interface (RS-485)

Dimensions (Scale Drawings)

IS06BBE-SX

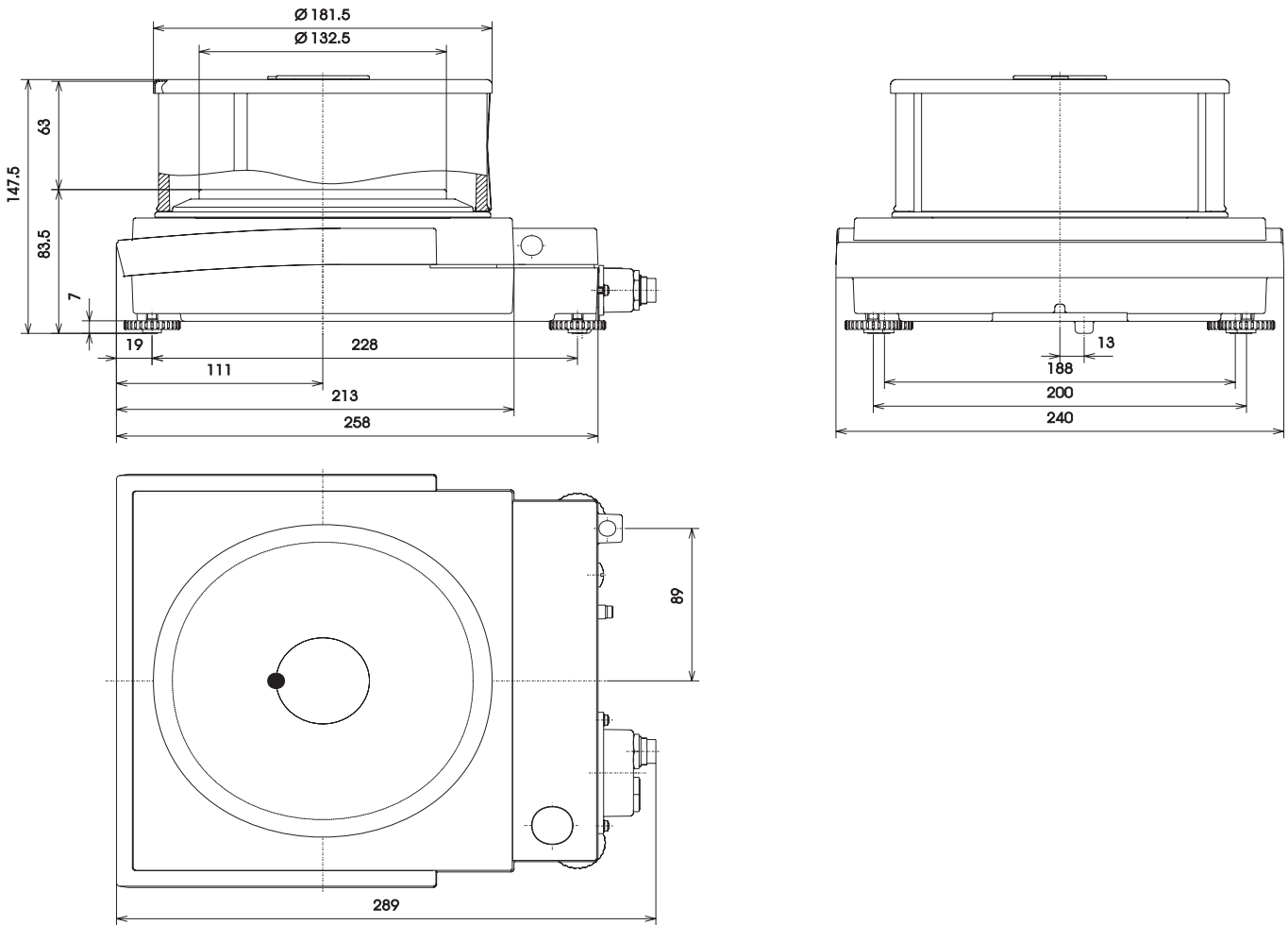

All dimensions given in millimeters

IS2CCE-SX, IS6CCE-HX

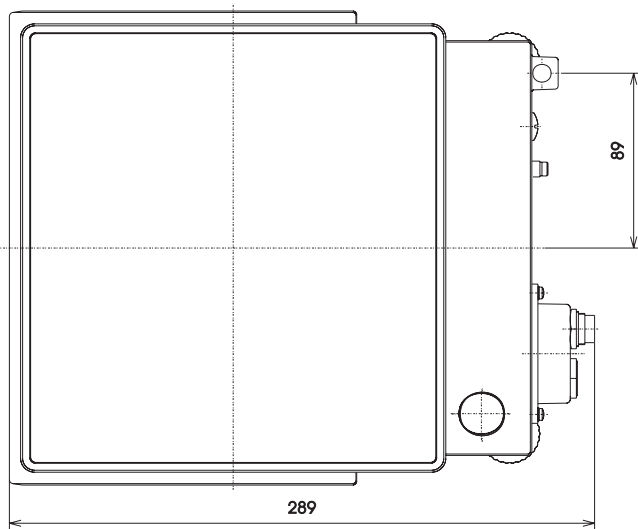
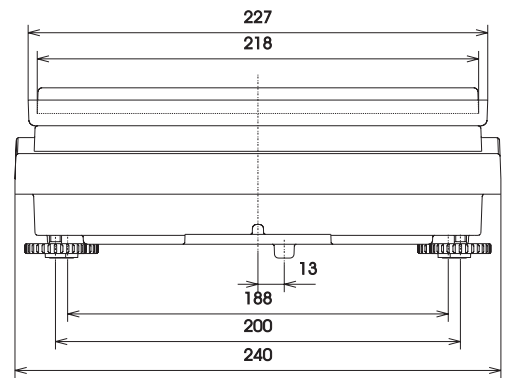
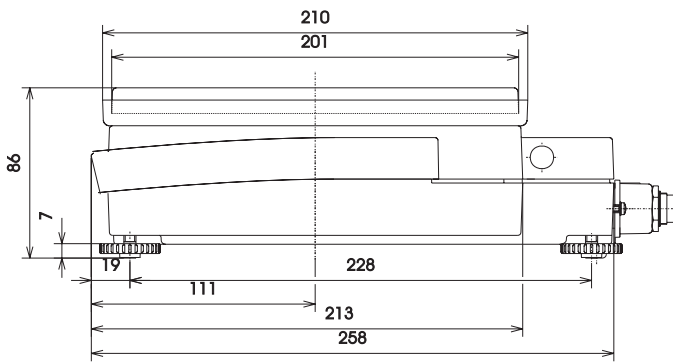

All dimensions given in millimeters

IS6CCE-SX, IS12CCE-SX

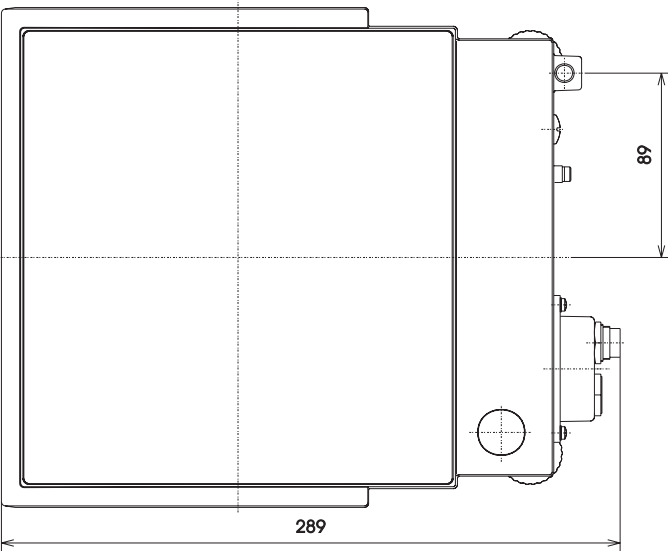
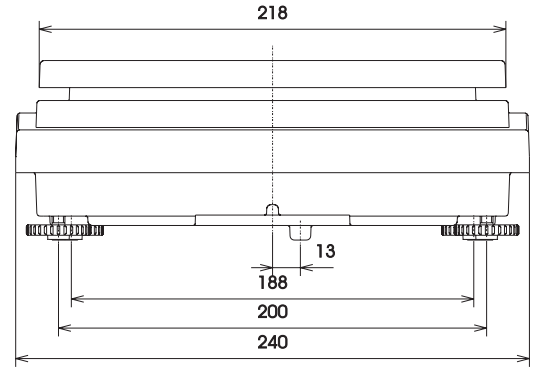
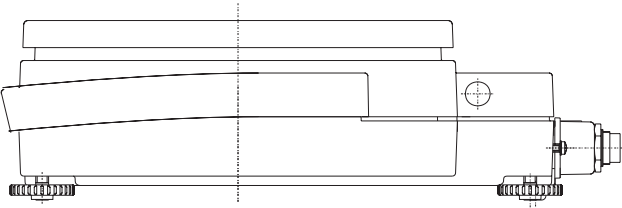

All dimensions given in millimeters

IS16EDE-HX, IS34EDE-HX, IS34EDE-HX, IS64EDE-SX

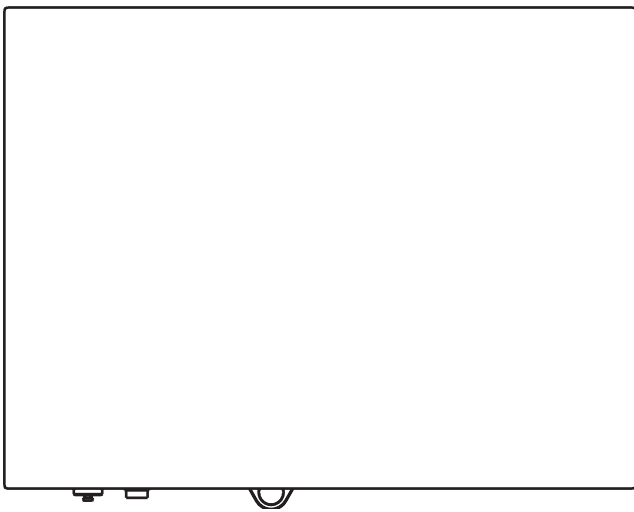
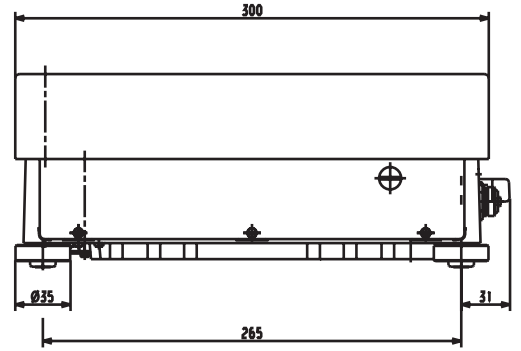
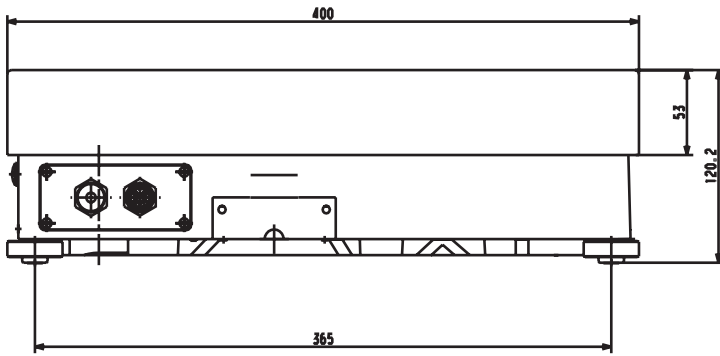

All dimensions given in millimeters

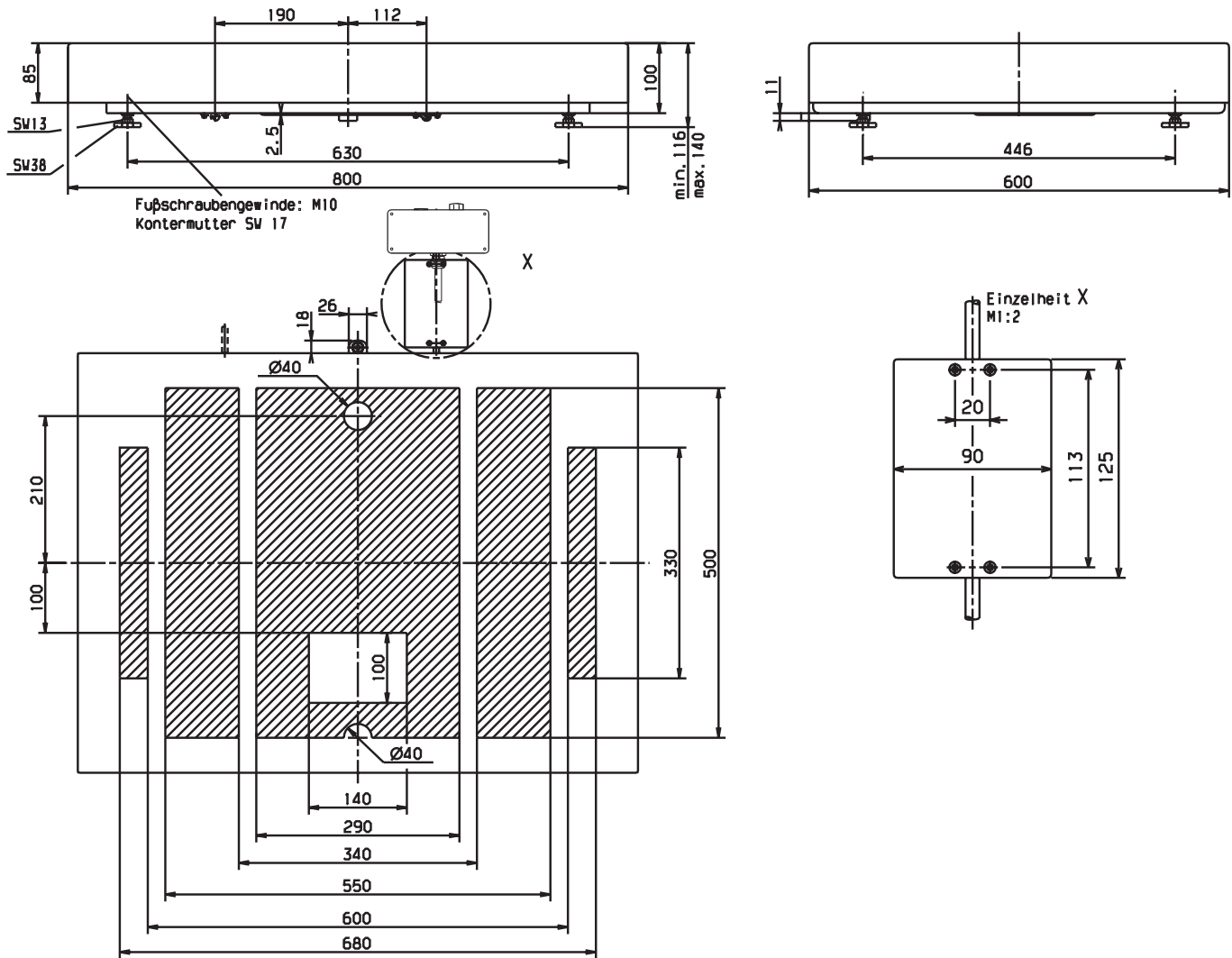

All dimensions given in millimeters

EC Verification" - A Service Offered by Minebea Intec

Our service technicians authorized to perform the verification of your weighing instruments that are acceptable for legal metrological verification can inspect and verify the metrological specifications at the place of installation within the Member States of the European Union and the Signatories of the Agreement on the European Economic Area.

Subsequent Verifications within the European Countries

The validity of the verification will become void in accordance with the national regulations of the country in which the weighing instrument is used. For information on verification and legal regulations currently applicable in your country, and to obtain names of the persons to contact, please contact your local Minebea Intec office, dealer or service center.



EU- / EG-Konformitätserklärung EU / EC Declaration of Conformity

Hersteller <i>Manufacturer</i>	Minebea Intec Bovenden GmbH & Co. KG Leinetal 2, 37120 Bovenden, Germany
	erklärt in alleiniger Verantwortung, dass das Betriebsmittel <i>declares under sole responsibility that the equipment</i>
Geräteart <i>Device type</i>	Wägeplattform <i>Weighing platform</i>
Baureihe <i>Type series</i>	IS06BBE-SX., IS2CCE-SX., IS6CCE-HX., IS6CCE-SX., IS12CCE-SX., IS16EDE-HX., IS34EDE-HX., IS64EDE-HX., IS64EDE-SX., IS150IGG-HX., IS300IGG-HX..
	in der von uns in Verkehr gebrachten Ausführung allen einschlägigen Bestimmungen der folgenden Europäischen Richtlinien – einschließlich deren zum Zeitpunkt der Erklärung geltenden Änderungen – entspricht und die anwendbaren Anforderungen folgender harmonisierter Europäischer Normen erfüllt: <i>in the form as delivered fulfils all the relevant provisions of the following European Directives – including any amendments valid at the time this declaration was signed – and meets the applicable requirements of the harmonized European Standards listed below:</i>
2014/30/EU	Elektromagnetische Verträglichkeit <i>Electromagnetic compatibility</i> EN 61326-1:2013
2006/42/EG 2006/42/EC	<u>Nur</u> für Geräte mit interner Justiergewichtsschaltung <u>Only</u> for devices with internal calibration weight Maschinen <i>Machines</i> EN ISO 12100:2010
2011/65/EU	Beschränkung der Verwendung bestimmter gefährlicher Stoffe in Elektro- und Elektronikgeräten (RoHS) <i>Restriction of the use of certain hazardous substances in electrical and electronic equipment (RoHS)</i> EN 50581:2012
2014/34/EU	Geräte und Schutzsysteme zur bestimmungsgemäßen Verwendung in explosionsgefährdeten Bereichen <i>Equipment and protective systems intended for use in potentially explosive atmospheres</i> EN 60079-0:2012, EN 60079-11: 2012, EN 60079-31:2014
Kennzeichnung <i>Marking</i>	II 2G EEx ib IIC T4 Gesamte Baureihe, <i>Entire type series</i> II 1D T135°C Nur <i>only</i> : IS16EDE-HX., IS34EDE-HX., IS64EDE-SX., IS150IGG-HX., IS300IGG-HX
Zertifizierung <i>Certification</i>	EG-Baumusterprüfbescheinigung Nummer: KEMA 01ATEX1099 X <i>EC-Type Examination Certificate number:</i>
QAN	Anerkennung der Qualitätssicherung Produktion FM16ATEXQ0084 <i>Quality Assurance Notification (production)</i>



EU- / EG-Konformitätserklärung EU / EC Declaration of Conformity

Jahreszahl der CE-Kennzeichenvergabe / Year of the CE mark assignment: 17

Die Person, die bevollmächtigt ist, die technischen Unterlagen zusammenzustellen:
The person authorised to compile the technical file:

Minebea Intec Bovenden GmbH & Co. KG, Research & Development, Leinetal 2, 37120 Bovenden,
Germany

Minebea Intec Bovenden GmbH & Co. KG
Bovenden, 2017-02-08



Dr. Bodo Krebs
President



Dr. Jörg Hachenberg
Head of Mechatronics

Diese Erklärung bescheinigt die Übereinstimmung mit den genannten EU/EG Richtlinien, ist jedoch keine
Zusicherung von Eigenschaften. Bei einer mit uns nicht abgestimmten Änderung des Produktes verliert diese
Erklärung ihre Gültigkeit. Die (Sicherheits-)Hinweise der zugehörigen Produktdokumentation sind zu beachten.

*This declaration certifies conformity with the above mentioned EU/EC Directives, but does not guarantee product
attributes. Unauthorised product modifications make this declaration invalid. The (safety) information in the
associated product documentation must be observed.*



Physikalisch-Technische Bundesanstalt

Braunschweig und Berlin



Prüfschein

Test Certificate

Ausgestellt für: Sartorius Industrial Scales GmbH & Co. KG
Issued to: Leinetal 2
 37120 Bovenden

Prüfgrundlage: DIN EN 45501 (1992) Nr. 8.1, Richtlinie 2009/23/EG, OIML R 76-1
In accordance with:

Gegenstand: Lastaufnehmer/Load receptor
Object: mit Wägezelle und Auswerteelektronik mit digitalem Ausgang als Modul einer elektromechanischen Waage zum Anschluß an geeignete Anzeige- und Bedienterminals/ with load cell and electronic device with digital output as module of an electromechanical weighing instrument for connection to suitable display- and operator-terminals

Typ: BA BF, BC BF, BD BF, BF BF, HC BF, MA BF, MD BF
Type:

Kennnummer:
Serial No.:

Prüfscheinnummer: D09-96.30 8. Revision
Test Certificate No.: D09-96.30 Revision 8

Datum der Prüfung:
Date of test:

Anzahl der Seiten: 13
Number of pages:

Geschäftszeichen: PTB-1.12-4065144
Reference No.:

Benannte Stelle: 0102
Notified Body:

Im Auftrag
 On behalf of PTB

Dr. Oliver Mack

Braunschweig, 17.09.2013

Siegel
 Seal



Im Auftrag
 On behalf of PTB

Timo Schwabe

PTB-0025 |

Prüfscheine ohne Unterschrift und Siegel haben keine Gültigkeit. Dieser Prüfschein darf nur unverändert weiterverbreitet werden. Auszüge bedürfen der Genehmigung der Physikalisch-Technischen Bundesanstalt.
 Test Certificates without signature and seal are not valid. This Test Certificate may not be reproduced other than in full. Extracts may be taken only with the permission of the Physikalisch-Technische Bundesanstalt.



Physikalisch-Technische Bundesanstalt
Nationales Metrologieinstitut

KBS

Konformitätsbewertungsstelle

PTB • Postfach 33 45 • 38023 Braunschweig

Minebea Intec Bovenden GmbH & Co. KG

Leinetal 2

D-37120 Bovenden

Your reference: Metrology Department
Your letter of:
My reference: PTB-1.1
My letter of:
Handled by: Dr.-Ing. D. Knopf
Telephone: +49 531 592 1100
Fax:
E-mail: dorothea.knopf@ptb.de
Date: 02.02.2017

Collective letter regarding the applicability of certificates

Dear Mr. Martin,

This is to inform you that the certificates listed below which the Conformity Assessment Body of PTB has issued to *Sartorius Industrial Scales GmbH & Co. KG* will be valid as of 29 November 2016 for *Minebea Intec Bovenden GmbH & Co. KG*. Based on the information currently available to us, *Minebea Intec Bovenden GmbH & Co. KG* has taken over all the rights and obligations of *Sartorius Industrial Scales GmbH & Co. KG*. This change will be taken into account in the case of any future revisions which may be issued to the certificates.

This applies to the following certificates:

EU Type-Approval Certificates:
D97-09-018, D07-09-010, DE-08-MI006-PTB040, DE-08-MI006-PTB034,

Evaluation Certificates according to WELMEC 8.8:
DE-15-EC-PTB002, DE-15-EC-PTB005,

and Test Certificates:
D09-11.02, D09-07.21, D09-06.13, D09-00.28, D09-00.18, D09-99.15, D09-96.30, D09-95.18,
D09-03.13, D09-07.56, D09-03.29, D09-99.06, D09-97.07, D09-96.19, D09-95.30, D09-95.20,
D09-95.09, D09-95.08

If you have any questions, please do not hesitate to contact us.

Sincerely yours,
On behalf of PTB

600 30 b

Hausadresse, Lieferanschrift:
Bundesallee 100
38116 Braunschweig
DEUTSCHLAND

Telefon: +49 531 592-0
Telefax: +49 531 592-9292
E-Mail: poststelle@ptb.de
De-Mail: poststelle@ptb.de-mail.de
Internet: <http://www.ptb.de>

Deutsche Bundesbank, Filiale Leipzig
IBAN: DE38 8800 0000 0086 0010 40
BIC: MARKDEF1860
VAT-Nr.: DE 811 240 952

PTB Berlin-Charlottenburg
Abbestr. 2-12
10587 Berlin
DEUTSCHLAND

Plates and Markings – IS... -CE + Terminals

Note: Protective seals of the indicating and operator terminal see belonging manuals.

Type BD BF

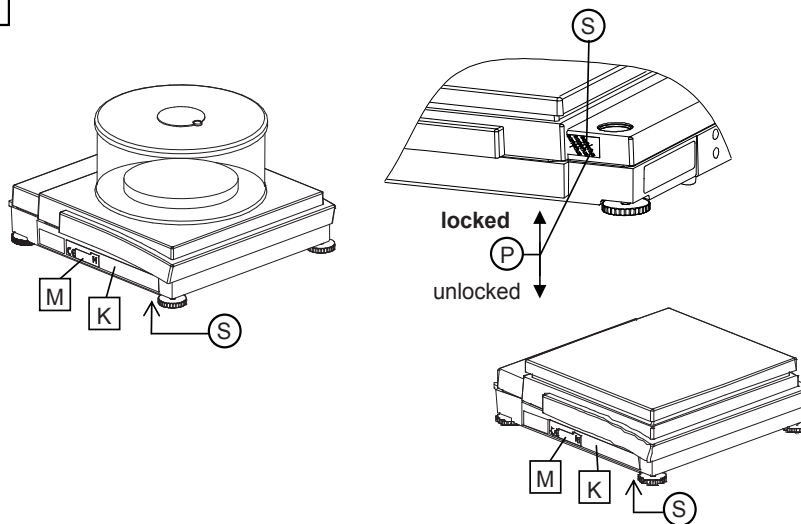

Type BF BF

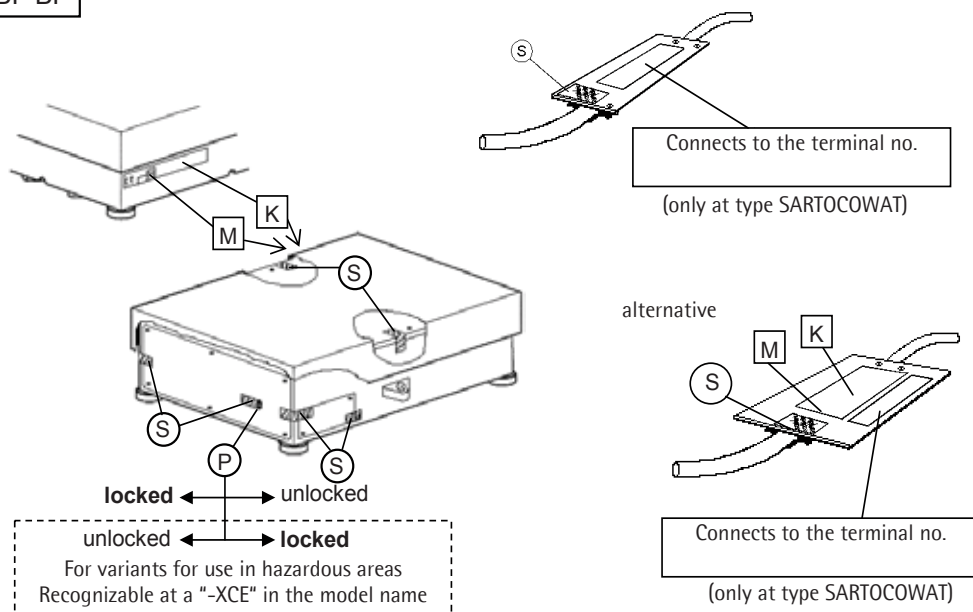

PPIS030511e

Type of weighing instrument: SARTOCOWAT Types of weighing modules: BD BF, BF BF, HA BD, HC BF
 EC Type-approval T7899 + Test certificates D09-96.30, D09-95.18

Type HA BD

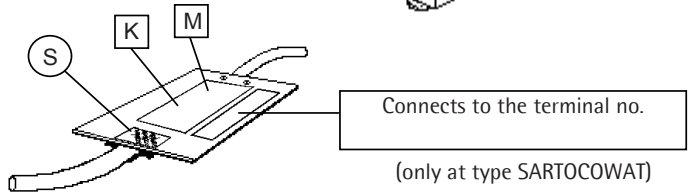
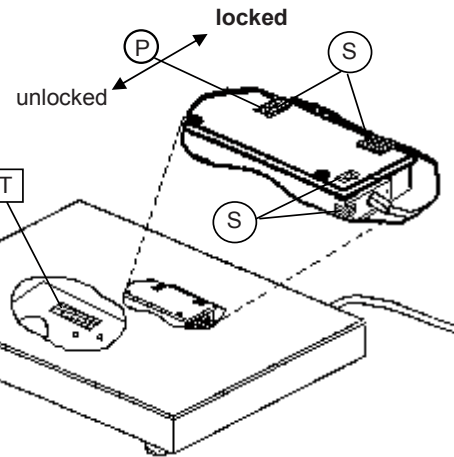
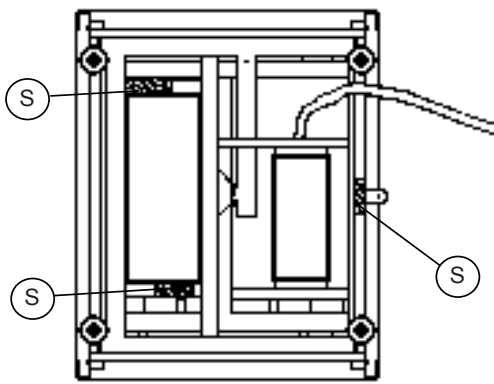

Type HC BF

For variants for use in hazardous areas
Recognizable at a "-XCE" in the model name
locked ← → **unlocked**

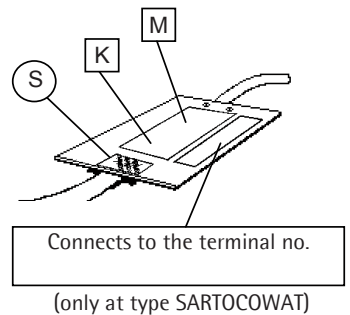
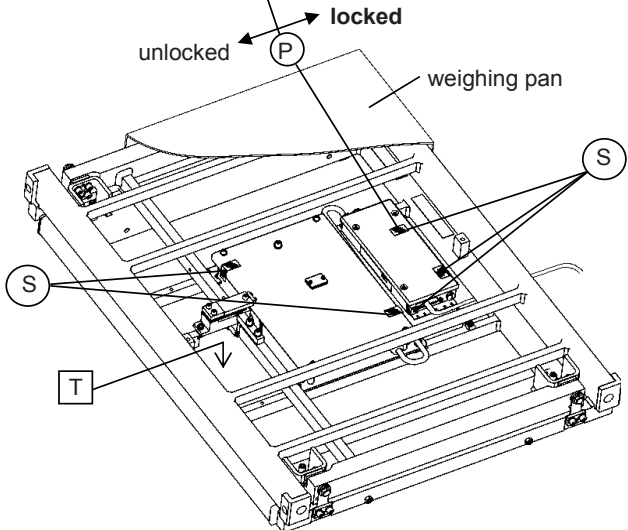

- K** Descriptive plate with CE-conformity mark
- M** Mark for EC verification (green metrology sticker)
- S** Protective seal

- T** Plate with model designation
- P** Menu access switch

PPIS030511e

Type of weighing instrument: SARTOCOWAT Types of weighing modules: BD BF, BF BF, HA BD, HC BF
EC Type-approval T7899 + Test certificates D09-96.30, D09-95.18

In connection with Terminals types TA (CAIS1, CAISL1, CAIS2, CAISL2, CAIS3, CAISL3

Example of descriptive of the already verified weighing instrument K

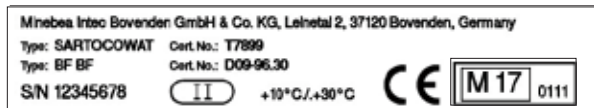

Example of plate with model designation - weighing module T

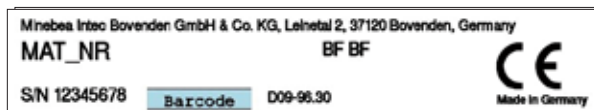

Example of plate with model designation - terminal T

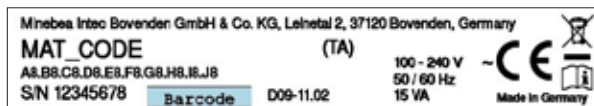

Type of weighing instrument: SARTOCOWAT types of modules BD BF, BF BF, HC BF, HA BD, EC Type-approval T7899 + Prüfschein D09-96-30, Do9-95-18

PPIS030511e/3



- (1) **EG-Baumusterprüfbescheinigung**
- (2) Gerät oder Schutzsystem zur bestimmungsgemäßen Verwendung in explosionsgefährdeten Bereichen – Richtlinie 94/9/EG.
- (3) EG-Baumusterprüfbescheinigung Nummer: **KEMA 01ATEX1099 X**
- (4) Gerät oder Schutzsystem :
- Wägemodul-Reihe, Typ IS.....-X.... und
Wägesystem-Reihe, Typ FC.....-X.... und
Wägesystem-Reihe, Typ FCA.....-X.... und
Wägesystem-Reihe, Typ FCB.....-X....**
- (5) Hersteller: **Sartorius AG**
- (6) Anschrift: **Weender Landstraße 94-108, 37075 Göttingen, Deutschland**
- (7) Die Bauart dieses Gerätes oder Schutzsystems sowie die verschiedenen zulässigen Ausführungen sind in der Anlage zu dieser Baumusterprüfbescheinigung festgelegt.
- (8) KEMA Quality B.V. bescheinigt als benannte Stelle Nr. 0344 nach Artikel 9 der Richtlinie 94/9/EG des Rates der Europäischen Gemeinschaften vom 23. März 1994 die Erfüllung der grundlegenden Gesundheits- und Sicherheitsanforderungen für die Konzeption und den Bau von Geräten und Schutzsystemen zur bestimmungsgemäßen Verwendung in explosionsgefährdeten Bereichen gemäß Anhang II der Richtlinie.
- Die Prüfung und Testergebnisse sind in dem vertraulichen Prüfbericht Nr. 2010745 festgelegt.
- (9) Die grundlegenden Gesundheits- und Sicherheitsanforderungen werden erfüllt durch Übereinstimmung mit:
- EN 50041: 1997 EN 50020: 1994**
- (10) Falls das Zeichen "X" hinter der Bescheinigungsnummer steht, wird auf besondere Bedingungen für die sichere Anwendung des Gerätes oder Schutzsystems in der Anlage zu dieser Bescheinigung hingewiesen.
- (11) Diese Baumusterprüfbescheinigung bezieht sich nur auf die Konzeption und den Bau des festgelegten Gerätes oder Schutzsystems gemäß der Richtlinie 94/9/EG. Falls erforderlich sind weitere Anforderungen dieser Richtlinie für die Herstellung und das Inverkehrbringen dieses Gerätes oder Schutzsystems zu erfüllen. Diese sind nicht Bestandteil der Bescheinigung.
- (12) Die Kennzeichnung des Gerätes muss die folgenden Angaben enthalten:



II 2 G EEx ib IIC T4

Arnhem, den 18. Oktober 2001
KEMA Quality B.V

T. Pijpker
Certification Manager

© Diese Bescheinigung einschließlich Anlage darf nur ungekürzt und unverändert weiterverbreitet werden.

KEMA Quality B.V.
Utrechtsweg 310, 6812 AR Arnhem,
Postfach 9035, 6800 ET Arnhem, Niederlande
Telefon +31 26 3 56 20 08, Telefax +31 26 3 52 58 00

Anerkannt vom
Niederländischen Rat
für Akkreditierung

(13)

ANLAGE

(14)

zur EG-Baumusterprüfbescheinigung KEMA 01ATEX1099 X(15) **Beschreibung**

Die Wägemodul-Reihen der Typen IS...BBE-X..., IS...CCE-X..., IS...EDE-X und IS...IGG-X... werden eingesetzt zum Messen von Gewichten und besitzen Anschlüsse zur Stromversorgung und zu einem externen Terminal für die Datenverarbeitung.

Je nach Modell bestehen die Verbindungen zum externen Terminal und zur Stromversorgung aus Steckern oder integrierten Kabeln, im letzteren Fall durch einen Anschlusskasten des Typs YAS06IS-X.

Die Wägemodule unterscheiden sich in Größe und Bauart, je nachdem, für welche Last sie ausgelegt sind.

Die Wägesystem-Reihen der Typen FC.....-X..., FCA.....-X... und FCB.....-X... werden eingesetzt zum Messen von Gewichten, zur Verarbeitung der Daten und zum Sicherstellen der Kommunikation zu anderen Einheiten (z.B.: einem PC). Das Wägesystem besteht aus einem der vorher erwähnten Wägemodulen und einem Terminal mit Anzeige und Tastatur.

Beim Typ FC.....-X... ist der Terminal integriert, bei den Modellen FCA.....-X... und FCB.....-X... ist das Terminal abgesetzt angeschlossen.

Alle Typen werden von 4 unabhängigen, eigensicheren Stromkreisen gespeist.

Alle Typen verfügen über identische Stromkreise für die Stromversorgung und Datenkommunikation.

Alle Typen besitzen externe Anschlüsse für passive Geräte (z.B.: einen Fußschalter).

Typ FCB.....-X... besitzt zusätzliche Ein-/Ausgabe-Stromkreise zum Anschluss von Ausgängen an zugehörige Stromkreise durch Barrieren und Eingangsstromkreise zu passiven Stromkreisen (z.B.: Schaltern).

Umgebungstemperaturbereich: -20°C ... +40°C

Elektrische DatenAlle Typen

Unless ...

Versorgungsstromkreise in der Zündschutzart Eigensicherheit EEx ib IIC,
nur für die Verbindung mit einem zertifizierten eigensicheren
Stromkreis mit folgenden Höchstwerten (für jeden Stromkreis):

Stromkreis	U_i	I_i	P_i	C_i	L_i
V-1	12,6 V	133 mA	1,68 W	0 nF	0 mH
V-2	12,6 V	133 mA	1,68 W	0 nF	0 mH
V-3	8,6 V	187 mA	1,61 W	300 nF	0 mH
V-4	12,6 V	150 mA	1,89 W	100 nF	0 mH

Stromkreis zur

Datenkommunikation in der Zündschutzart Eigensicherheit EEx ib IIC,
mit folgenden Höchstwerten (pro Stromkreis,
wenn nicht anders erwähnt):

$$U_o = 8,6 \text{ V}$$

$$I_o = 23 \text{ mA}$$

$$P_o = 50 \text{ mW}$$

Die höchste zulässige externe Kapazität $C_o = 6 \mu\text{F}$,
die höchste zulässige externe Induktivität $L_o = 60 \text{ mH}$.

Seite 2/5

(13)

ANLAGE

(14)

zur EG-Baumusterprüfbescheinigung KEMA 01ATEX1099 X**Elektrische Daten** (Fortsetzung)

Stromkreise nur zum Anschluss an einen zertifizierten eigensicheren Stromkreis, mit folgenden Höchstwerten (für jeden Stromkreis pro anwendbare Anschlusskombination):

Stromkreis	U _i [V]	I _i [mA]	P _i [mW]	C _i [nF]	L _i [mH]	Anschlüsse	Anmerkung
RS232	12,6	85	270	3	0	A/J/K/N/M (BU9) oder 9/10/11/12/8 (BU6)	1)
RS232	12,6	10	30	4	0	C/D/E/F/G/M (BU9) oder 2/3/4/5/6/8 (BU6)	1)
RS485	12,6	85	270	110	0	J/K/L/M (BU9) oder 3/4 (BU30) + 9/10 (BU6)	1)
RS485	12,6	10	30	4	0	C/D/E/F/G/M (BU9) oder 6/11/8 (BU6)	1)
TTY	14,7	50	265	0	0	G/K/D/F/J (BU9) oder 3/7/2/4/6 (BU30)	1)
TTY	14,7	130	100	0	0	C/E/D/F/J (BU9) oder 1/5/2/4/6 (BU30)	1) 2)
I/O- Ausgang	30	120	900	0	0	1/2, 3/4, 5/6, 7/8 (ST 20)	1) 3)

Anmerkungen:

- 1) Der Strom I_i muss ohmsch begrenzt sein.
- 2) Kann alternativ angeschlossen werden an den Wandler Typ 725324, zertifiziert durch die Konformitätsbescheinigung PTB Nr. Ex-85.B.2089.
Für diese Kombination gelten folgende Daten:
Die höchste zulässige externe Kapazität C_o = 620 nF und die höchste zulässige externe Induktivität L_o = 2 mH.
- 3) Nur für das Modell FCB.....-X....

Höchstwerte für Ausgabedaten (für jeden Stromkreis pro anwendbare Anschlusskombination):

Stromkreis	U _o [V]	I _o [mA]	P _o [mW]	C _o [nF]	L _o [mH]	Anschlüsse	Anmerkung
RS232	12,6	28	88	1,15	50	B/O/M (BU9) oder 1/7/8 (BU6)	1)
RS485	12,6	28	85	1,15	50	B/O/M (BU9) oder 7/8 (BU6)	1)
TTY	12,6	28	85	1,15	50	7/8 (BU6) oder 7/8 (BU6)	1) 2)
I/O- Eingang	12,6	30	95	1.15	50	9/10, 9/11, 9/12 (ST20)	3)

Anmerkungen:

- 1) Nur zum Einsatz in Verbindung mit passiven eigensicheren Stromkreisen
- 2) Derselbe Stecker wird mit oder ohne Anschlusskasten eingesetzt
- 3) Nur für Typ FCB.....-X....

Seite 3/5

(13)

A N L A G E(14) **zur EG-Baumusterprüfbescheinigung KEMA 01ATEX1099 X****Elektrische Daten** (Fortsetzung)

Anschlüsse nach Typ

Wägemodul-Reihe,Typ IS...BBE-X..., IS...CCE-X..., IS...EDE-X... und IS...IGG-X...

Anschlüsse:

- Versorgungsstromkreise: ST8 Pin 6/1 (V_1), 4/2 (V_2), 5/3 (V_3), 7/8 (V_4),
in Verbindung mit dem Anschlusskasten: BU2 Pin 6/1 (V_1), 4/2 (V_2), 5/3 (V_3), 7/8 (V_4)
- Stromkreise zur Datenkommunikation: BU9 (Pinbelegung siehe oben),
in Verbindung mit dem Anschlusskasten: BU6 + BU30 (Pinbelegung siehe oben)
- Bei Einsatz des Anschlusskastens:
die maximale Kabellänge zwischen Wägemodul und Anschlusskasten vom Typ YAS06IS-X beträgt 15 m.

Wägesystem-Reihe, Typ FC.....-X...

Anschlüsse:

- Versorgungsstromkreise: BU2 Pin 6/1 (V_1), 4/2 (V_2), 5/3 (V_3), 7/8 (V_4)
- Stromkreise zur Datenkommunikation: BU9 (Pinbelegung siehe oben)

Wägesystem-Reihe, Typ FCA.....-X...

Anschlüsse:

- Versorgungsstromkreise: ST8 Pin 6/1 (V_1), 4/2 (V_2), 5/3 (V_3), 7/8 (V_4)
- Daten- und Kommunikationsstromkreise: BU9 (Pinbelegung siehe oben)
- Maximale Kabellänge zwischen Wägemodul und Terminal beträgt 15 m

Wägesystem-Reihe, Typ FCB.....-X...

Anschlüsse:

- Versorgungsstromkreise: ST8 6/1 (V_1), 4/2 (V_2), 5/3 (V_3), 7/8 (V_4)
- Daten- und Kommunikationsstromkreise: BU9
- Maximale Kabellänge zwischen Wägemodul und Terminal beträgt 15 m

(16) **Bericht**

KEMA Nr. 2010745

(17) **Besondere Bestimmungen für den sicheren Gebrauch**

1. Die Ausgangsstromkreise der I/Os beim Typ FCB.....-X... dürfen nur an einseitig geerdeten Shuntioden-Zenerbarrieren angeschlossen werden. Diese Erdung und der externe Erdungsanschluss des Terminalgehäuses im Typ FCB.....-X... müssen an das Potential-Ausgleichssystem innerhalb des explosionsgefährdeten Bereichs angeschlossen werden.
2. Umgebungstemperaturbereich und Elektrische Daten, siehe (15).

Seite 4/5

(13)

A N L A G E(14) **zur EG-Baumusterprüfbescheinigung KEMA 01ATEX1099 X**(18) **Grundlegende Gesundheits- und Sicherheitsanforderungen**

Grundlegende Gesundheits- und Sicherheitsanforderungen, die nicht abgedeckt sind von den unter (9) erwähnten Normen	
Abschnitt	Thema
1.0.5	Kennzeichnung
1.0.6 (b) und (d)	Betriebsanleitung

Diese grundlegenden Gesundheits- und Sicherheitsanforderungen sind geprüft und positiv beurteilt worden. Die Prüfergebnisse sind abgelegt in dem unter (16) erwähnten Prüfbericht.

(19)

Prüfungsunterlagen

1. EG-Baumusterprüfbescheinigung KEMA 98ATEX0612 X
EG-Baumusterprüfbescheinigung KEMA 00ATEX1012 X

Datiert

- | | |
|--|------------|
| 2. Beschreibung (34 Seiten) | 02.02.2001 |
| 3. Zeichnung-Nr. 35520-000-60-A4 (3 Blätter) | 20.02.2001 |
| 4. Muster | |

Übersetzung (Maßgeblich ist die englischsprachige Originalfassung)

NACHTRAG 1

zur EG-Baumusterprüfbescheinigung KEMA 01ATEX1099 X

Hersteller: **Sartorius AG**

Anschrift: **Weender Landstraße 94-108, 37075 Göttingen, Deutschland**

Beschreibung

Die Wägemodul-Reihe Typ IS...EDE-.X..., IS...IGG-.X..., die Wägesystem-Reihe Typ FCA.....-X..., FCB.....-X... und der Kabelanschlusskasten Typ YAS06IS-X werden zukünftig alternativ in Übereinstimmung mit der EN 50281-1-1:1998 und den nachfolgenden Angaben angefertigt.

Die Kennzeichnung für diese Versionen lautet dann

 II 2 G EEx ib IIC T4 und  II 1 D T 135 °C

Die maximale Oberflächentemperatur des Gehäuses von T 135 °C basiert auf einer Umgebungstemperatur von 40 °C.

Die elektrischen Daten der Wägemodul-Reihe Typ IS...BBE-.X..., IS...CCE-.X..., IS...EDE-.X..., IS...IGG-.X... und der Wägesystem-Reihe Typ FC.....-X..., FCA.....-X..., FCB.....-X... sind im Nachfolgenden beschrieben.

Elektrische Daten

Stromkreis für den Datenausgang
für Einheiten mit einem RS-485 –
Stromkreis ...
(BU9)

in der Zündschutzart Eigensicherheit EEx ib IIC,
mit folgenden Höchstwerten:

$$\begin{aligned} U_o &= 12,6 \text{ V} \\ I_o &= 85 \text{ mA} \\ P_o &= 270 \text{ mW} \end{aligned}$$

Die maximal erlaubte externe Kapazität $C_o = 1,15 \text{ uF}$,
die maximal erlaubte externe Induktivität $L_o = 5 \text{ mH}$.

Nur für die Verbindung mit einem zertifizierten eigensicheren Stromkreis mit folgenden Höchstwerten.

Anschlüsse J/K:

$$\begin{aligned} U_i &= 12,6 \text{ V (jeder Stromkreis zu Erde)} \\ I_i &= 810 \text{ mA (ohmsch begrenzt)} \\ P_i &= 2,5 \text{ W} \end{aligned}$$

Die effektive interne Kapazität $C_i = 10 \text{ nF}$,
die effektive interne Kapazität L_i ist vernachlässigbar klein.

Anschlüsse D/E/F/G & M (Werte für jeden Stromkreis):

$$\begin{aligned} U_i &= 12,6 \text{ V} \\ I_i &= 10 \text{ mA (ohmsch begrenzt)} \\ P_i &= 30 \text{ mW} \end{aligned}$$

Die effektive interne Kapazität $C_i = 4 \text{ nF}$,
die effektive interne Kapazität ist vernachlässigbar klein.

Anschlüsse B/C/O/L nur zum Einsatz in Verbindung mit passiven eigensicheren Stromkreisen, die effektive interne Kapazität $C_i = 4 \text{ nF}$, die effektive interne Induktivität L_i ist vernachlässigbar klein.

Seite 1/2

NACHTRAG 1

zur EG-Baumusterprüfbescheinigung KEMA 01ATEX1099 X

Elektrische Daten (Fortsetzung)

Alle anderen Daten bleiben unverändert.

Besondere Bestimmungen für den sicheren Gebrauch

Bei Anwendungen der Wägemodul-Reihe, Typ IS....EDE-.X...., IS....IGG-.X...., der Wägesystem-Reihe, Typ FCA.....-X...., FCB.....-X.... und des Kabelanschlusskastens, Typ YAS06IS-X in explosionsgefährdeter Atmosphäre, die durch Luft-/Staubgemische bedingt ist, darf die Staubschicht nicht dicker sein als 5mm.

Alle anderen Daten bleiben unverändert.

Prüfungsunterlagen

	<u>Datiert</u>
1. Beschreibung	16.11.2001
2. Zeichnung-Nr.	
65638-000-39-A4	10.10.2000
65651-000-55-A3	25.09.2001
65638-000-55-A3 (2 Blätter)	11.09.2001
65638-000-55-A3	11.09.2001
98100-036-30 Rev.00	04.10.2000
98100-036-31 Rev.00	04.10.2000
65638-700-90-A4 Rev.00	06.10.2000
65552-000-05-A4	02.02.2001
35520-700-30-A3	14.10.2001
35632-210-02-A4	28.05.2001
98100-031-25-A4 Rev.01	19.09.1995

Arnhem, 08.Mai 2002
Im Auftrag der Direktion der N.V. KEMA

T. Pijker
Certification Manager
(Zertifizierungsleiter)



(1) **EG-BAUMUSTERPRÜFBESCHEINIGUNG**

- (2) Geräte und Schutzsysteme zur bestimmungsgemäßen Verwendung in explosionsgefährdeten Bereichen - Richtlinie 94/9/EG
- (3) EG-Baumusterprüfbescheinigung Nummer: **KEMA 98ATEX0892 X**
- (4) Gerät oder Schutzsystem: **Netzgerät Typ YPS02-X..**
- (5) Hersteller: **Sartorius AG**
- (6) Anschrift: **Weender Landstr. 94-108, 37075 Göttingen, Germany**
- (7) Die Bauart dieses Gerätes sowie die verschiedenen zulässigen Ausführungen sind in der Anlage zu dieser Baumusterprüfbescheinigung festgelegt.
- (8) KEMA bescheinigt als benannte Stelle Nr. 0344 nach Artikel 9 der Richtlinie 94/9/EG des Rates der Europäischen Gemeinschaften vom 23. März 1994 die Erfüllung der grundlegenden Sicherheits- und Gesundheitsanforderungen für die Konzeption und den Bau von Geräten und Schutzsystemen zur bestimmungsgemäßen Verwendung in explosionsgefährdeten Bereichen gemäß Anhang II der Richtlinie.
- Die Ergebnisse der Prüfung sind in dem vertraulichen Prüfbericht Nr. 80892 festgelegt.
- (9) Die grundlegenden Sicherheits- und Gesundheitsanforderungen werden erfüllt durch Übereinstimmung mit:
- EN 50014 : 1992 + prA1 EN 50018 : 1994 EN 50020 : 1994**
- (10) Falls das Zeichen "X" hinter der Bescheinigungsnummer steht, wird auf besondere Bedingungen für die sichere Anwendung des Gerätes in der Anlage zu dieser Bescheinigung hingewiesen.
- (11) Diese EG-Baumusterprüfbescheinigung bezieht sich nur auf die Konzeption und den Bau des festgelegten Gerätes oder Schutzsystemes. Falls erforderlich, sind weitere Anforderungen dieser Richtlinie für die Herstellung und das Inverkehrbringen dieser Geräte oder Schutzsysteme zu erfüllen.
- (12) Die Kennzeichnung des Gerätes oder Schutzsystemes muß die folgenden Angaben enthalten:



II 2 (2) G EEx d [ib] IIC T4

Arnhem, den 15. Juni 1998
im Auftrag der Direktion der N.V. KEMA

C.M. Boschloo
Certification Manager

Blatt 1/4

ANLAGE

(13)

(14)

zur EG-Baumusterprüfbescheinigung KEMA 98ATEX0892 X
(15) **Beschreibung**

Das Netzgerät Typ YPS02-X.. stellt 4 unabhängige eigensichere Ausgangskanäle für eigensichere Waagen zur Verfügung. Das Netzgerät ist in ein Gehäuse montiert, das die Schutzart "d" (druckfeste Kapselung) aufweist. Die Maximallänge des Datenkabels Typ LiYC-Y-CY 4 * 0.5 zwischen Netzgerät und Waagen beträgt 50 m.

Zulässiger Umgebungstemperaturbereich: 0°C + 40°C

Elektrische Daten

Netzversorgung 1 nicht eigensicherer Stromkreis, geeignet für Verbindung zu elektrischen Betriebsmitteln mit Betriebsspannungen bis 264 V.

Versorgungs- u. in der Zündschutzart Eigensicherheit
Eingangstromkreis
Anschluß (V_1, weiß) EEx ib IIC mit folgenden Höchstwerten:

$$\begin{aligned} U_o &= 12,6 \text{ V} \\ I_o &= 133 \text{ mA} \\ P_o &= 1,68 \text{ W} \end{aligned}$$

Höchste zulässige externe Kapazität $C_o = 1 \mu\text{F}$
Höchste zulässige externe Induktivität $L_o = 300 \mu\text{H}$

Versorgungs- u. in der Zündschutzart Eigensicherheit
Eingangstromkreis
Anschluß (V_2, braun) EEx ib IIC mit folgenden Höchstwerten:

$$\begin{aligned} U_o &= 12,6 \text{ V} \\ I_o &= 133 \text{ mA} \\ P_o &= 1,68 \text{ W} \end{aligned}$$

Höchste zulässige externe Kapazität $C_o = 1 \mu\text{F}$
Höchste zulässige externe Induktivität $L_o = 300 \mu\text{H}$

Versorgungs- u. in der Zündschutzart Eigensicherheit
Eingangstromkreis
Anschluß (V_3, grün) EEx ib IIC mit folgenden Höchstwerten:

$$\begin{aligned} U_o &= 8,6 \text{ V} \\ I_o &= 187 \text{ mA} \\ P_o &= 1,61 \text{ W} \end{aligned}$$

Höchste zulässige externe Kapazität $C_o = 4 \mu\text{F}$
Höchste zulässige externe Induktivität $L_o = 300 \mu\text{H}$

Versorgungs- u. in der Zündschutzart Eigensicherheit
Eingangstromkreis
Anschluß (V_4, gelb) EEx ib IIC mit folgenden Höchstwerten:

$$\begin{aligned} U_o &= 12,6 \text{ V} \\ I_o &= 150 \text{ mA} \\ P_o &= 1,89 \text{ W} \end{aligned}$$

Höchste zulässige externe Kapazität $C_o = 1 \mu\text{F}$
Höchste zulässige externe Induktivität $L_o = 300 \mu\text{H}$

Blatt 2/4

(13)

ANLAGE

(14)

zur EG-Baumusterprüfbescheinigung KEMA 98ATEX0892 X(15) **Elektrische Daten (Fortsetzung)**

Kabel Typ LiYC-Y-CY 4 * 0.5

Maximale Kabelkapazität $C_{\text{kabel}} = 28,2 \text{ nF}$ Maximale Kabelinduktivität $L_{\text{kabel}} = 8,4 \text{ } \mu\text{H}$

Maximale zulässige Kabellänge = 50 m

Die eigensicheren Stromkreise sind unfehlbar galvanisch isoliert von den nicht eigensicheren Stromkreisen bis zu der Summe der Höchstspannungen von 375 V.

Installationsanweisung

Das Netzgerät, das mit zertifizierten Kabeleingängen Typ ADE versehen wird, kann nur für feste Installation benutzt werden. Zertifizierte Kabeleingänge Typ AGRO können für feste oder flexible Installation benutzt werden.

Routinemäßige Prüfungen

Der Transformator muß vor dem Einbau in das Betriebsmittel gemäß Klausel 8.1.5 der EN 50 020 - 1994 dem Anlegen von 2500 V zwischen Primär- und Sekundär-Wicklung ohne Zusammenbruch widerstehen.

Routinemäßige Prüfungen gemäß Klausel 16 der EN 50 018 sind nicht notwendig, da die Baumusterprüfung bei einem statischen Druck durchgeführt wurde, der ein 4-fach des Referenzdrucks aufwies.

(16) **Prüfbericht**

KEMA Nr. 80892

(17) **Besondere Bedingungen für den sicheren Gebrauch**

keine

(18) **Grundlegende Sicherheits- und Gesundheitsanforderungen**

Grundlegende Sicherheits- und Gesundheitsanforderungen, die nicht abgedeckt sind von den unter (9) erwähnten Normen	
Abschnitt	Thema
1.0.6	Betriebsanleitung

Diese grundlegenden Sicherheits- und Gesundheitsanforderungen sind geprüft und positiv beurteilt worden. Die Prüfergebnisse sind abgelegt in dem unter (16) erwähnten Prüfbericht.

Blatt 3/4

ANLAGE

(13)

(14)

zur EG-Baumusterprüfbescheinigung KEMA 98ATEX0092 X

(19) **Prüfungsunterlagen**

- | | | |
|----------------------------------|--------------------|------------|
| 1. EG-Baumusterprüfung | PTB 98ATEX1023 U | |
| Konformitätsbescheinigung | KEMA 98ATEX0611 X | |
| | ISSeP 92.C.103.997 | |
| | LCIE 92.C6125 X | |
| 2. Beschreibung 65473-000-06-A4, | | 05.05.1998 |
| Rev. 00(11 Blatt) | | |
| 3. Zeichnung Nr. 65473-700-06-A4 |) | |
| 65473-000-33-A3 |) | 05.05.1998 |
| 65473-700-05-A3 |) | |
| 65473-000-05-A2 | | 02.02.1998 |
| 65473-120-90-A3 |) | |
| 65473-120-95-A3 |) | 09.01.1998 |
| 65473-120-01 |) | |
| 4. Muster | | |

Blatt 4/4

Übersetzung

(Maßgeblich ist die englischsprachige Originalfassung)

Nachtrag 1

zur EG-Baumusterprüfbescheinigung KEMA 98ATEX0892 X

Hersteller: **Sartorius AG**Anschrift: **Weender Landstraße 94-108, 37075 Göttingen, Deutschland****Beschreibung**

Zukünftig wird das Netzgerät Typ YPS02-X.. alternativ in Übereinstimmung mit EN 50281-1-1:1998 und der nachfolgenden Dokumentation hergestellt.

Das Kennzeichen für diese Version lautet

 II 2 G EEx d[ib] IIC T4 und  1 D T 135 °C

Die maximale Oberflächentemperatur des Gehäuses von T 135 °C basiert auf einer Umgebungstemperatur von 40 °C.

Elektrische Daten

Der Wert der maximalen Leistung für jeden einzelnen Versorgungs- und Eingangsstromkreis ändert sich wie folgt:

Anschluss V_1, weiß : P_o = 1,46 W
 Anschluss V_2, braun : P_o = 1,46 W
 Anschluss V_3, grün : P_o = 1,51 W
 Anschluss V_4, gelb : P_o = 1,68 W

Alle anderen Daten bleiben unverändert.

Besondere Bedingungen für den sicheren Gebrauch

1. Bei Anwendungen in explosionsfähigen Atmosphären bedingt durch Luft-/Staubgemische darf die Staubschicht nicht dicker sein als 5 mm.
2. Umgebungstemperaturbereich und Elektrische Daten siehe (15) und oben.

Prüfungsunterlagen

		<u>Datiert</u>
1. Zeichnungs-Nr.	65473-000-36-A4	10.10.2000

Arnheim, den 11 April 2002
 KEMA Quality B.V.

T. Pijpker
 Certification Manager

NACHTRAG 1

zur EG-Baumusterprüfbescheinigung KEMA 01ATEX1099 X

Elektrische Daten (Fortsetzung)

Alle anderen Daten bleiben unverändert.

Besondere Bestimmungen für den sicheren Gebrauch

Bei Anwendungen der Wägemodul-Reihe, Typ IS....EDE-.X...., IS....IGG-.X...., der Wägesystem-Reihe, Typ FCA.....-X...., FCB.....-X.... und des Kabelanschlusskastens, Typ YAS06IS-X in explosionsgefährdeter Atmosphäre, die durch Luft-/Staubgemische bedingt ist, darf die Staubschicht nicht dicker sein als 5mm.

Alle anderen Daten bleiben unverändert.

Prüfungsunterlagen

		<u>Datiert</u>
1. Beschreibung		16.11.2001
2. Zeichnung-Nr.	65638-000-39-A4	10.10.2000
	65651-000-55-A3	25.09.2001
	65638-000-55-A3 (2 Blätter)	11.09.2001
	65638-000-55-A3	11.09.2001
	98100-036-30 Rev.00	04.10.2000
	98100-036-31 Rev.00	04.10.2000
	65638-700-90-A4 Rev.00	06.10.2000
	65552-000-05-A4	02.02.2001
	35520-700-30-A3	14.10.2001
	35632-210-02-A4	28.05.2001
	98100-031-25-A4 Rev.01	19.09.1995

Arnhem, 08.Mai 2002
Im Auftrag der Direktion der N.V. KEMA

T. Pijpker
Certification Manager
(Zertifizierungsleiter)

Circuit:	V1	V2	V3	V4
Uo	12.6 V	12.6 V	8.6 V	12.6V
Io	133 mA	133 mA	187 mA	150 mA
Po	1.46 W	1.46 W	1.51 W	1.68 W
Co	1µF	1µF	4 µF	1 µF
Lo	300µH	300 µH	300 µH	300 µH

Power supply
YPS02-Z.R

II (2) G
[EEEx ib] IIC
II (1) D

Non hazardous area

Power supply
YPS02-X.R

II 2 G
EEEx d [ib] IIC T4
II 1 D T135°C

Alternative Connection

Sartorius cable: type LiYC-Y-CY 4 x 0,5²
(permanently installed on power supply; can be flexibly installed)
max. Length = 50 m
max. L_{Cable} = 8.4 µH
max. C_{Cable} = 28.2 nF

IIC T4

Compact scale
FC.....-X....
FCA.....-X....

Weighing platform
IS.....-X....

II 2 G EEEx ib IIC T4
II 1 D T135°C (optional)

Hazardous area

Circuit:	V1	V2	V3	V4
Uo	12.6 V	12.6 V	8.6 V	12.6V
Io	133 mA	133 mA	187 mA	150 mA
Po	1.46 W	1.46 W	1.51 W	1.68 W
Co	1µF	1µF	4 µF	1 µF
Lo	300µH	300 µH	300 µH	300 µH

Circuit:	V1	V2	V3	V4
Ui	12.6 V	12.6 V	8.6 V	12.6V
Ii	133 mA	133 mA	187 mA	150 mA
Pi	1.68 W	1.68 W	1.61 W	1.89 W
Ci	0	0	300 nF	100 nF
Li	0	0	0	0

EX	Date	Name	FC/FCA/IS.....-X.... /	Power Supply	Sheet	1
Written by	12.02.02	Klausgrete		Verification of the Intrinsic Safety	of	4
Reviewed by	12.02.02	Weitemeier			Rev.	
Released by	12.02.02	Klausgrete			35520-099-61-A4	00

Barrier
YDI02-Z
YDI03-Z

II (2) G
[EEEx ib] IIC

Circuit:	RS-232 ¹⁾	Control signals (only for YDI03-Z) ¹⁾
Uo	12 V	12 V
Io	82 mA	7.5 mA
Po	240 mW	22 mW
Co	1.41 µF	1.41 µF
Lo	5.5 mH	5.5 mH
Lo/Ro	144µH/Ω	1.5 mH/Ω

Non hazardous area

Cable: install as stationary and protected equipment !
Maximum cable length 70m for a 10-wire standard cable with a maximum of 200 nF/km and 1mH/km.

The length of the installed cable is defined as 20 m because of the RS-232 specifications.

Data output¹⁾

Uo	8,6 V
Io	23 mA
Po	50 mW
Co	6 µF
Lo	60 mH

Data output RS-232 (pins A/J/K/N and M)¹⁾

Ui	12.6 V
Ii	85 mA
Pi	270 mW
Ci	3 nF
Li	0

Control signals (pins C/D/E/F/G and M)¹⁾

Ui	12.6V
Ii	10 mA
Pi	30 mW
Ci	4 nF
Li	0

IIC T4

T-connektor²⁾
YTE02-X

Foot actuated switch²⁾
YPE05-X

Compact scale
FC.....-X....
FCA.....-X....

Weighing platform
IS.....-X....

II 2 G EEEx ib IIC T4
II 1 D T135°C (optional)

Hazardous area

System appraisal
(see EC-Type Examination Certificate KEMA 02ATEX1108 X):
Co <= 125nF; Lo <= 100µH; Lo/Ro <= 33µH/Ω

1: per circuit
2: optionally used (passive wiring or switch only)

EX	Date	Name	FC/FCA/IS.....-X.... /RS-232 data output with control lines	Sheet	2	
Written by	12.02.02	Klausgrete		Verification of the Intrinsic Safety	of	4
Reviewed by	12.02.02	Weitemeier			Rev.	
Released by	12.02.02	Klausgrete			35520-099-61-A4	00

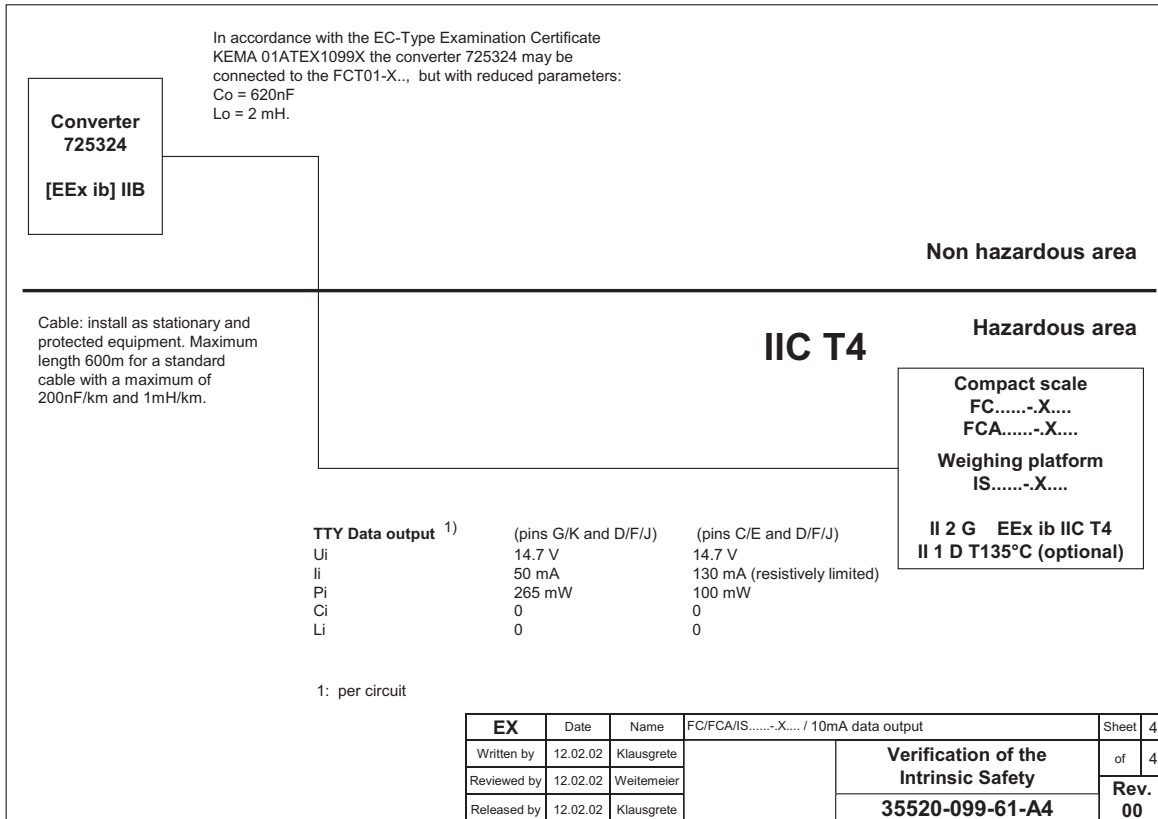
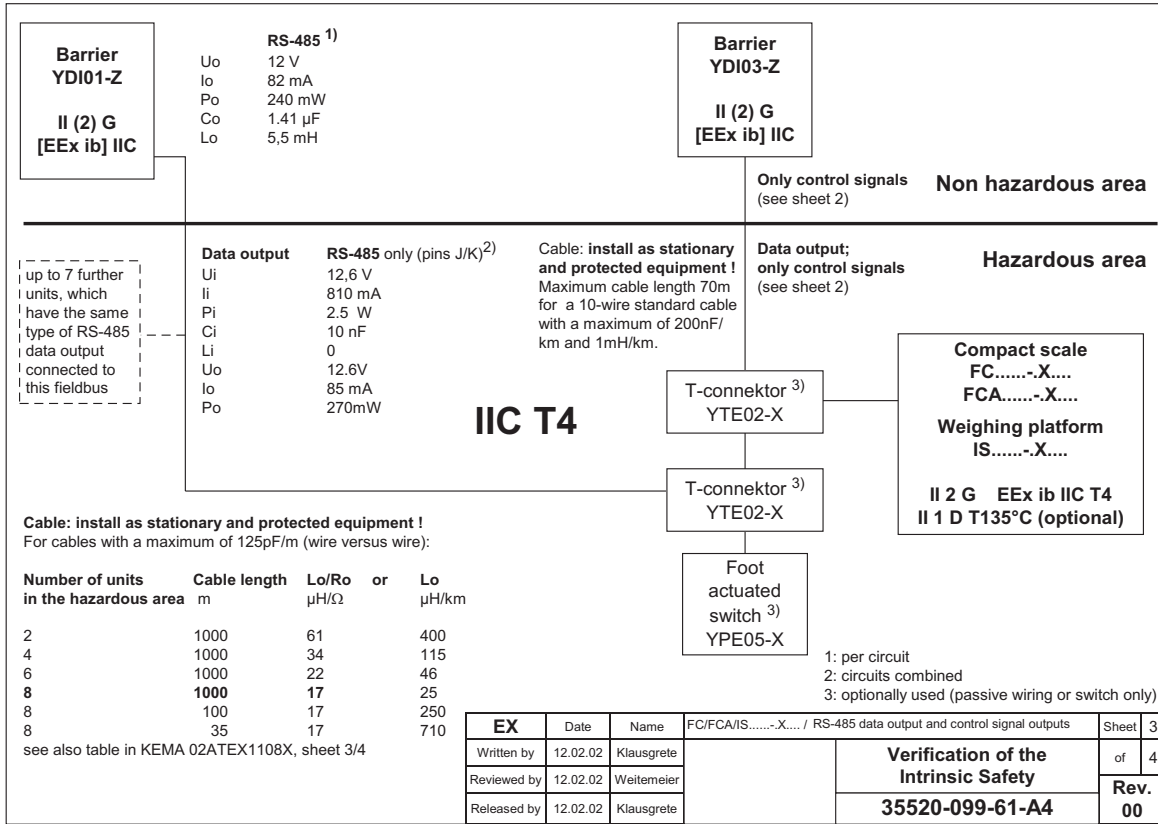

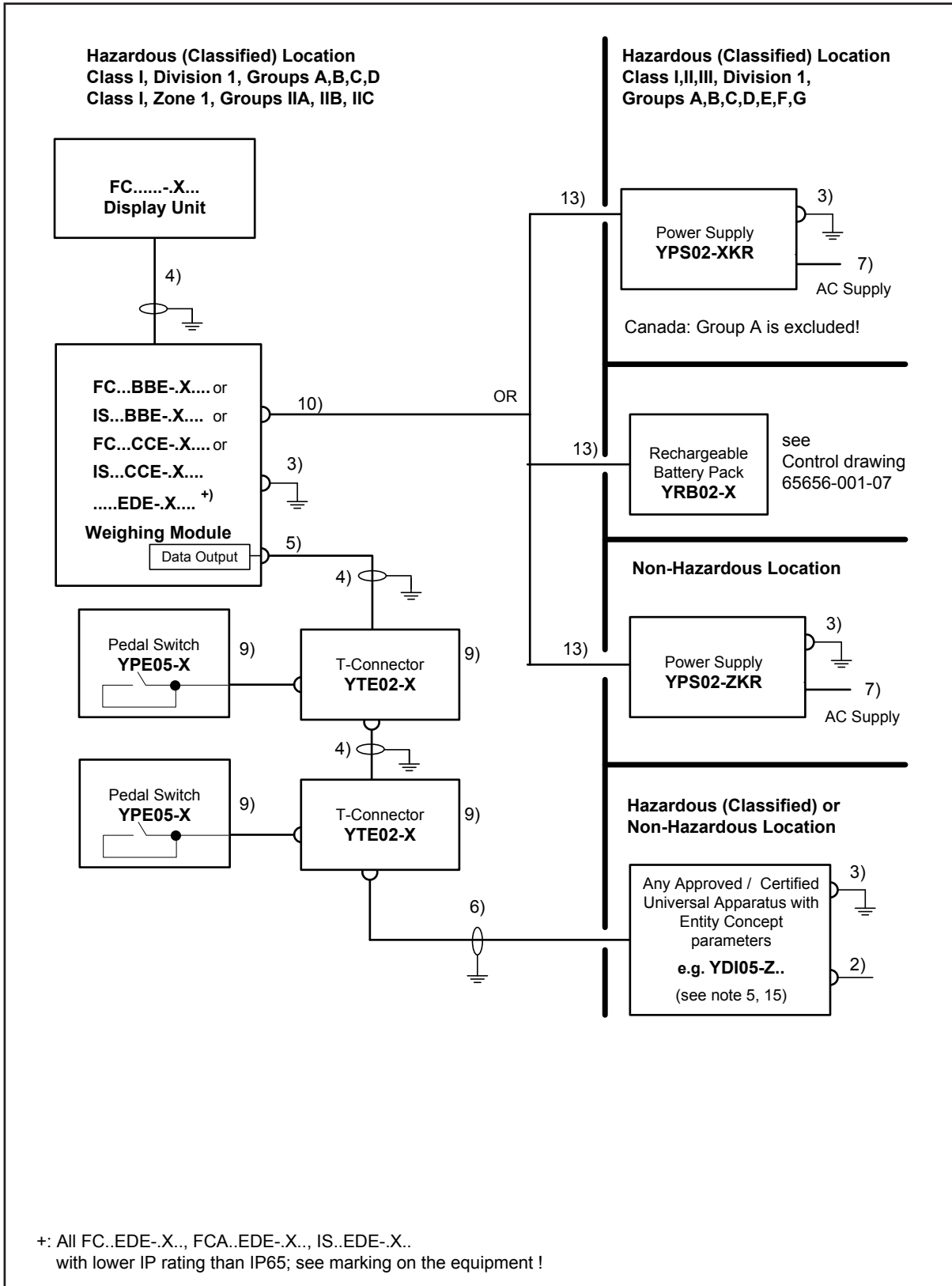

	Date	Name		Title	Control Drawing			
Written by	2011-07-07	Klausgrete		Drawing number	33956-000-07-A4	Revision	04	Sheet 1 of 5
Reviewed by	2011-07-07	Klausgrete		Released by	2011-07-07	Klausgrete		

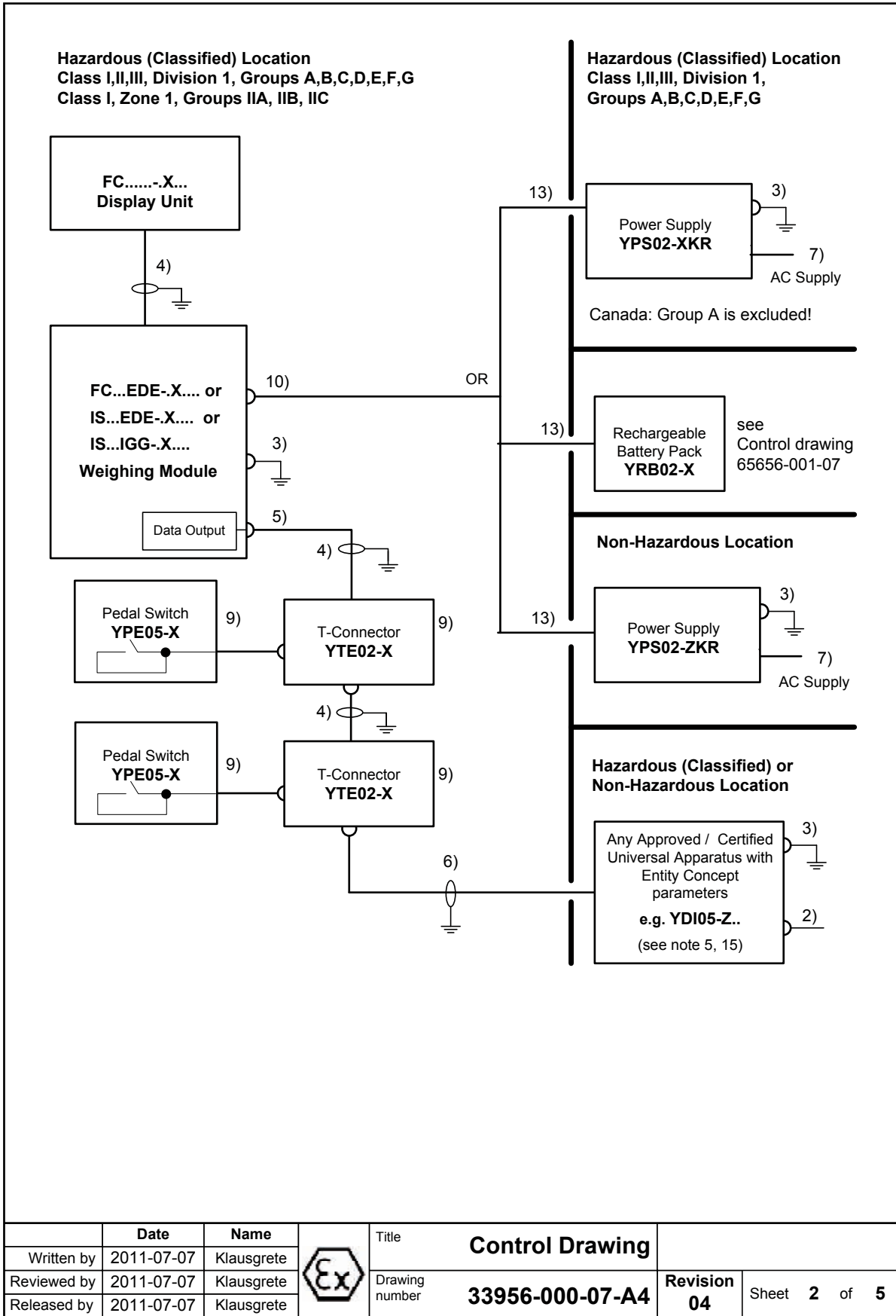

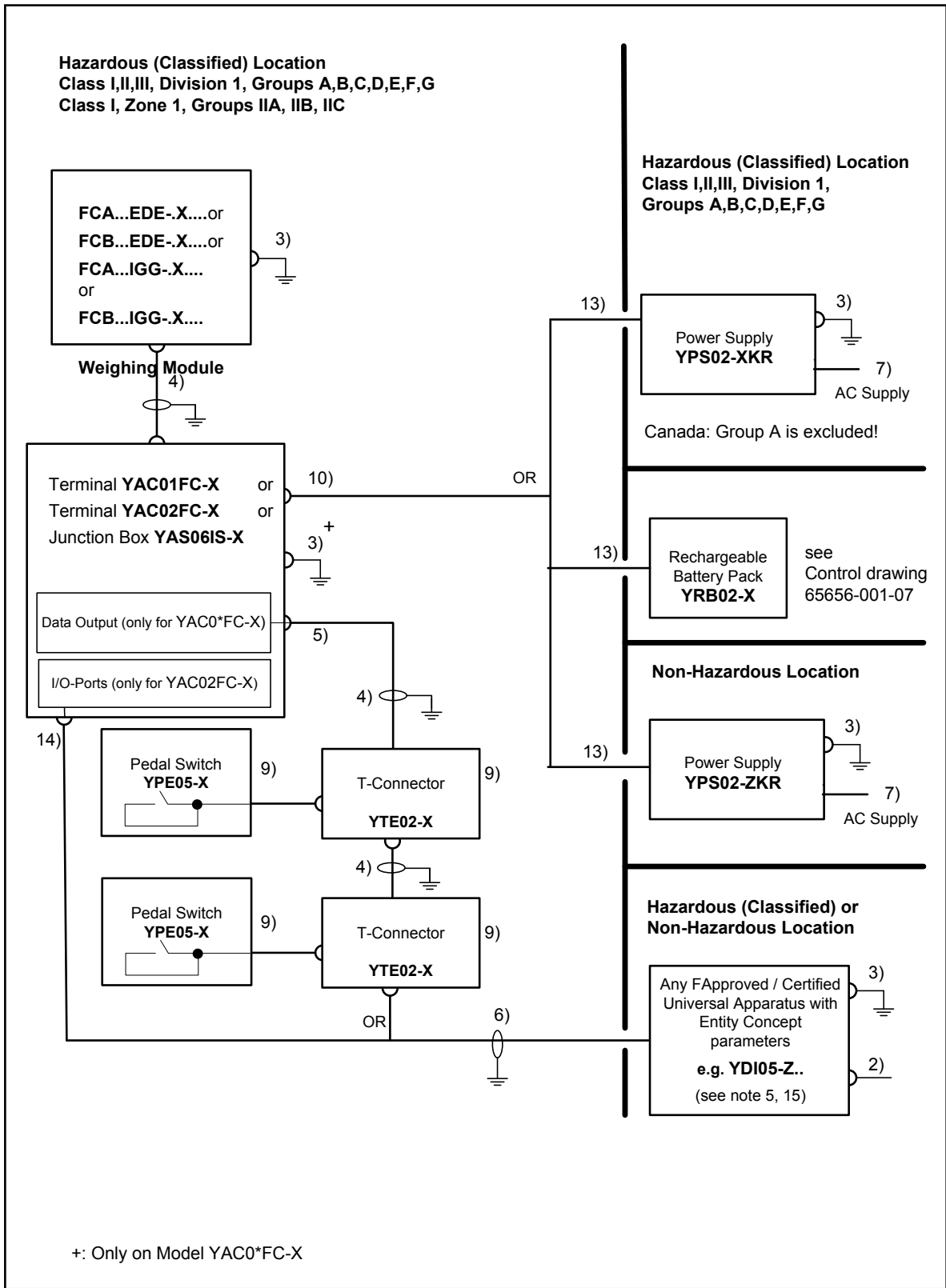

	Date	Name		Title			
Written by	2011-07-07	Klausgrete		Control Drawing			
Reviewed by	2011-07-07	Klausgrete		Drawing number	33956-000-07-A4	Revision	
Released by	2011-07-07	Klausgrete			04	Sheet	3 of 5

ENTITY DATA FOR TERMINAL:

Data Output (Pos. 5) Input Parameters :

RS232 (combined circuits): (Pin A/J/K/N/M):	U _i = 12.6 V U _i = 25,2 V **	l _i = 340 mA *	P _i = 1.08 W	C _i = 2 nF	Li = 15 µH
RS422 (combined circuits): (Pin A/B/C/E/F/G/J/K/M/N):	U _i = 7.5 V	l _i = 500 mA *	P _i = 900 mW	C _i = 5.5 µF	Li = 17 µH
RS485 (combined circuits): (Pin J/K/L/M):	U _i = 12.6 V	l _i = 810 mA *	P _i = 2.5 W	C _i = 12 nF	Li = 15 µH
Control Signals on RS232 or RS485 (per circuit): (Pin C/D/E/F/G/M):	U _i = 12.6 V	l _i = 10 mA	P _i = 30 mW	C _i = 4 nF	Li = 0
(Pin B/O) only for use in combination with simple apparatus:				C _i = 4 nF	Li = 0
TTY (Pin G/K and D/F/J):	U _i = 14.7 V	l _i = 50 mA	P _i = 265 mW	C _i = 2 nF	Li = 15 µH
	(Pin C/E and D/F/J):		U _i = 14.7 V	l _i = 130 mA	P _i = 100 mW
C _i = 2 nF L _i = 15 µH L _o = 2mH	The circuits may be connected to the converter Type 725324-1:				C _o = 620nF

Data Output (Pos. 5) Output Parameters (combined circuits):

RS232 (combined circuits): (Pin A/J/K/N/M):	U _o = 12.6 V U _o = 25,2 V **	l _o = 131 mA *	P _o = 411 mW	C _o = 1.15 µF C _o = 107 nF **	L _o = 2 mH
RS422 (combined circuits): (Pin A/B/C/E/F/G/J/K/M/N):	U _o = 12.6 V	l _o = 180 mA *	P _o = 570 mW	C _o = 1.15 µF	L _o = 0.7 mH
Lo/Ro = 62 µH/ohm					
RS485 (combined circuits): (Pin J/K/L/M):	U _o = 12.6 V	l _o = 85 mA *	P _o = 270 mW	C _o = 1.15 µF	L _o = 5 mH
Lo/Ro = 118 µH/ohm					

Maximum length for a typical standard data cable:

- RS232** limited by the RS232 standard to 25m (82 feet)
- RS422** 500 m (1,640 feet) for Group A,B,C,D and IIA, IIB, IIC; 1000 m (3,280 feet) for Group C, D and IIA, IIB
- TTY** 300 m (984 feet) for 1,200 bit/s; 150 m (492 feet) for 2,400 bit/s; 65 m (213 feet) for 4,800 bit/s; 30 m (98 feet) for 8,600 bit/s; 15 m (49 feet) for 19,200 bit/s; for Group A,B,C,D and IIA, IIB, IIC
- RS485** up to 1000 m (3,280 feet)
with up to 8 Minebea Intec scales type FC/FCA/IS.....-X... or CIXS3-.. or WZ.....-X.. CW3X...-..... or FCT01-X..

when connected to Minebea Intec **Interface Converter YDI05-Z..** or **Barrier YDI01-Z..** or **YDI02-Z..**
the Barriers YDI0.-Z.. contain Z966 zener barriers from Pepperl & Fuchs.

	Date	Name		Title			
Written by	2011-07-07	Klausgrete		Control Drawing			
Reviewed by	2011-07-07	Klausgrete		Drawing number	33956-000-07-A4	Revision	Sheet 4 of 5
Released by	2011-07-07	Klausgrete			04		

- 1) In the USA: The installation must be in accordance with the National Electrical Code ®, NFPA 70, Article 504 or 505 and ANSI / ISA-RP 12.6.
In Canada: The installation must be in accordance with the Canadian Electrical Code ®, Part1, Section 18.
- 2) The apparatus must not be connected to any device that uses or generates in excess of 250Vrms or DC.
- 3) In the USA: The apparatus must be connected to a suitable ground electrode per National Electrical Code ®, NFPA 70, Article 504 or 505. The resistance of the ground pad must be less than 1 ohm.
In Canada: The apparatus must be connected to a suitable ground electrode per Canadian Electrical Code ®, Part 1. The resistance of the ground pad must be less than 1 ohm.
- 4) The cable to the terminal model YAC01LA-X00FC and to the T-Connector model YTE02-X must be protected against damage.
- 5) The Entity Concept allows interconnection of intrinsically safe apparatus with associated apparatus not specifically examined in combination as a system when the approved values of Voc, Isc and Pmax resp. Uo, Io, Po of the associated apparatus are less than or equal to Vmax, Imax and Pmax resp. Ui, Ii, Pi of the intrinsically safe apparatus and the approved values of Ca and La resp. Co and Lo of the associated apparatus are greater than Ci and Li of the intrinsically safe apparatus plus all cable parameters.
- 6) In the USA: Optionally, the cable of any FMRC Approved Universal Apparatus with Entity Concept parameters (see note 5) can be connected directly to the data output of the weighing module; this cable must be protected against damage.
In Canada: Optionally, the cable of any CSA Certified Universal Apparatus with Entity Concept parameters (see note 5) can be connected directly to the data output of the weighing module; this cable must be protected against damage.
- 7) The apparatus must not be connected to any device that uses or generates in excess of 132Vrms or DC.
- 8) The cable to the terminal model YAC01FC-X or model YAC02FC-X needs not be protected against damage.
- 9) In the USA: These units are considered as non-certified simple apparatus. The levels as indicated for simple apparatus in FMRC Class 3610 shall not be exceeded in this simple apparatus.
In Canada: These units are considered as non-certified simple apparatus. The temperature class of the apparatus has to be determined. Per Levels generated in the simple apparatus as indicated in Table 3 of CAN/CSA-E79-11-95.
When the parameters of the apparatus are not specified, based on the entity parameters of the weighing module output the temperature class has to be determined and the capacitance and inductance of the interconnecting cable may not exceed the Co and the Lo.
- 10) Connection by means of polarized connector.
- 11) Ambient temperature range: 0°C +40°C (32°F + 104°F)
- 12) WARNING: SUBSTITUTION OF COMPONENTS MAY IMPAIR INTRINSIC SAFETY.
AVERTISSEMENT: LA SUBSTITUTION DE COMPOSANTS PEUT COMPROMETTRE LA SÉCURITÉ INTRINSÈQUE.
- 13) Connection by non interchangeable cable type LiYC-Y-CY 4 x 0.5; max length: 50m (164 ft).
- 14) The Entity Concept allows interconnection of intrinsically safe apparatus with associated apparatus not specifically examined in combination as a system when the approved values of Voc, Isc and Pmax resp. Uo, Io, Po of the associated apparatus are less than or equal to Vmax, Imax and Pmax resp. Ui, Ii, Pi of the intrinsically safe apparatus and the approved values of Ca and La resp. Co and Lo of the associated apparatus are greater than Ci and Li of the intrinsically safe apparatus plus all cable parameters.
The output circuits of the optional I/O of Type FCB must be connected to grounded shunt diode barriers; this ground to be connected with the P.E. within the hazardous area.
- 15) The Minebea Intec Interface Converter YDI05-Z.. is approved/certified by FM for USA and Canada. See Certificate of Compliance and Control Drawing number 65710-800-07-A4.
Furthermore Minebea Intec Barriers YDI01-Z.. and YDI02-Z.. may be used, which contain FM and CSA approved / certified Z966 zener barriers from Pepperl & Fuchs.
- 16) **WARNING: USE WET OR DAMP CLOTH TO CLEAN TO AVOID ELECTRIC STATIC DISCHARGE.**

	Date	Name		Title	Control Drawing		
Written by	2011-07-07	Klausgrete		Drawing number			
Reviewed by	2011-07-07	Klausgrete					
Released by	2011-07-07	Klausgrete					

Minebea Intec Bovenden GmbH & Co. KG
Leinetal 2
37120 Bovenden, Germany

Phone +49.551.309.83.0
Fax +49.551.309.83.190

www.minebea-intec.com

Copyright by Minebea Intec,
Bovenden, Germany.

No part of this publication may be reprinted or translated in any form or by any means without prior written permission from Minebea Intec. All rights reserved.

The status of the information, specifications and illustrations in this manual is indicated by the date given below. Minebea Intec reserves the right to make changes to the technology, features, specifications, and design of the equipment without notice.

Date: September 2017

Printed in Germany on paper that has been bleached without any use of chlorine
RS .KT
Publication No.:WIS6019-e17093